

Instruction Manual

Diffstak[®] Mk2 Diffusion Pumps
Diffstak 63/150, 100/300, 160/700
and 250/2000, M-, P-, C- and F-models



This page has been intentionally left blank.



Declaration of Conformity

We, Edwards Limited,
Crawley Business Quarter,
Manor Royal,
Crawley,
West Sussex, RH10 9LW, UK

declare under our sole responsibility, as manufacturer and person within the EU authorised to assemble the technical file, that the product(s)

Diffstak 63

B34431976	B34437978
B34431977	B34438976
B34431978	B34438977
B34432976	B34438978
B34432977	B34442220
B34432978	B34442240
B34433976	B34455200
B34433977	B34455220
B34433978	B34455277
B34437976	B34456220
B34437977	B34456240

Diffstak 100

B34631976	B34637976
B34631977	B34637977
B34631978	B34637978
B34632976	B34638976
B34632977	B34638977
B34632978	B34638978
B34633976	B34640976
B34633977	B34640977
B34633978	B34640978

to which this declaration relates is in conformity with the following standard(s) or other normative document(s)

EN1012-2:1996, A1: 2009 Compressors and Vacuum Pumps. Safety Requirements.
Vacuum Pumps

and fulfils all the relevant provisions of

2006/42/EC Machinery Directive
2006/95/EC Low Voltage Directive

Note: This declaration covers all product serial numbers from the date this Declaration was signed onwards.

Peter Meares, GV Technical Support Manager

18.10.2013, Burgess Hill

Date and Place

This product has been manufactured under a quality system certified to ISO9001:2008



Declaration of Conformity

We, Edwards Limited,
Crawley Business Quarter,
Manor Royal,
Crawley,
West Sussex, RH10 9LW, UK

declare under our sole responsibility, as manufacturer and person within the EU authorised to assemble the technical file, that the product(s)

Diffstak 160

B34831976 B34837976
B34831977 B34837977
B34831978 B34837978
B34832976 B34838976
B34832977 B34838977
B34832978 B34838978
B34833976 B34840976
B34833977 B34840977
B34833978 B34840978

Diffstak 250

B35031976 B35033977
B35031977 B35033978
B35031978 B35037977
B35032976 B35037978
B35032977 B35038978
B35032978 B35043978
B35033976

to which this declaration relates is in conformity with the following standard(s) or other normative document(s)

EN1012-2:1996, A1: 2009 Compressors and Vacuum Pumps. Safety Requirements.
Vacuum Pumps

and fulfils all the relevant provisions of

2006/42/EC Machinery Directive
2006/95/EC Low Voltage Directive

Note: This declaration covers all product serial numbers from the date this Declaration was signed onwards.

Peter Meares, GV Technical Support Manager

18.10.2013, Burgess Hill

Date and Place

This product has been manufactured under a quality system certified to ISO9001:2008

Contents

Section	Page
1	Introduction 1
1.1	Scope and definitions 1
1.2	Description 2
1.3	Construction 3
1.4	Principle of operation 3
2	Technical data 9
2.1	General 9
2.1.1	M-model and P-model pumps 9
2.1.2	C-model and F-model pumps 10
2.2	Pump fluid data 10
2.3	Construction materials 11
2.4	Item Numbers 11
3	Installation 15
3.1	Safety 15
3.2	Unpack and inspect 15
3.3	Locate the pump 16
3.4	Vacuum connections 16
3.4.1	Diffstak inlet 16
3.4.2	Backing and roughing connections 21
3.5	Cooling-water connections 22
3.6	Electrical connections 22
3.6.1	Connect the electrical supply to the pump 22
3.6.2	Connect the cooling-fail thermal snap-switch (optional) 24
3.6.3	Connect the pump-ready thermal snap-switch (optional) 24
3.6.4	Connect the high-vacuum isolation-valve position indicators (63/150P and 100/300P only) 25
3.6.5	Connect the high-vacuum isolation-valve position indicators (160/700P and 250/2000P pumps only) 25
3.7	Connect the compressed-air supplies (P-model pumps only) 26
3.8	Leak-test the system 26
3.9	Fill the pump with fluid 27
3.9.1	Safety of vapour pump fluids 27
3.9.2	Recommended pump fluids 28
3.9.3	Filling procedure 29
4	Operation 31
4.1	Introduction 31
4.2	Pump start-up 31
4.3	Re-admission of air to your vacuum system 34
4.4	Re-evacuation of your vacuum system 34
4.5	Pump shut-down 34

5	Maintenance	35
5.1	Safety	35
5.2	Maintenance plan	36
5.3	Check the pump fluid-level	36
5.4	Inspect the pump fluid (and drain if necessary)	37
5.5	Inspect and clean the pump	37
5.5.1	Preparation	37
5.5.2	Remove the high-vacuum isolation-valve (M-model pumps)	37
5.5.3	Remove the high-vacuum isolation-valve (P-model pumps)	38
5.5.4	Dismantle the pump	38
5.5.5	Inspect and clean the interior	40
5.5.6	Reassemble the pump	40
5.6	Clean the radiation shield	42
5.7	Lubricate/inspect the high-vacuum isolation-valve (M- and P-model pumps)	43
5.8	Replace the pump heater(s)	44
5.8.1	Diffstak 63/150 and 100/300 pumps	44
5.8.2	Diffstak 160/700 and 250/2000 pumps	45
5.9	Check the heater securing nuts	46
5.10	Clean the cooling-coil	46
5.11	Adjust or replace the position indicators	46
5.11.1	Adjust the position indicators	46
5.11.2	Replace the position indicators	46
5.12	Fault finding	48
6	Storage and disposal	49
6.1	Storage	49
6.2	Disposal	49
7	Service, spares and accessories	51
7.1	Introduction	51
7.2	Service	51
7.3	Spares	51
7.3.1	Pump fluids	51
7.3.2	Spares common to all Diffstak pumps	52
7.3.3	Spares for Diffstak M- and P-model pumps	52
7.4	Accessories	53

For return of equipment, complete the HS Forms at the end of this manual.

Illustrations

Figure	Page
1	Sectional view of valved Diffstak 63/150 pump 4
2	Sectional view of valved Diffstak 100/300 pump 5
3	Sectional view of valved Diffstak 160/700 pump 6
4	Part sectional view of valved Diffstak 250/2000 pump 7
5	Dimensions of M-model Diffstak pumps (mm) 12
6	Dimensions of P-model Diffstak pumps (mm) 13
7	Dimensions of C-model Diffstak pumps (mm) 14
8	Inlet-flange fitting details 17
9	M- and P-model Diffstak inlet connection 18
10	F-model Diffstak inlet connection 18
11	C-model Diffstak inlet connection 18
12	Diffstak 63/150, 100/300 and 160/700 installation detailsn 19
13	Diffstak 250/2000 installation details 20
14	Heater electrical connections 23
15	Cooling-fail thermal snap-switch electrical connections 24
16	Position indicator connections (160/700P and 250/2000P only) 25
17	Schematic diagram of typical pneumatic circuit (P-model pumps only) 28
18	Typical pumping system: Diffstak 63/150, 100/300 and 160/700 pumps 32
19	Typical pumping system: Diffstak 250/2000 pumps 33
20	High-vacuum isolation-valve: Diffstak 63/150, 100/300 and 160/700 pumps 39
21	High-vacuum isolation-valve: Diffstak 250/2000 pumps 39
22	Pneumatic actuator for the isolation-valve: Diffstak 63/150P and 100/300P pumps 41
23	Pneumatic actuator for the isolation-valve: Diffstak 160/700P pumps 41
24	Pneumatic actuator for the isolation-valve: Diffstak 250/2000P pumps 41
25	Heater assembly: Diffstak 63/150 and 100/300 pumps 44
26	Heater assembly: Diffstak 160/700 and 250/2000 pumps 45
27	Adjust or replace the position indicators 47

Tables

Table	Page
1	Inlet-flange details (M-, P- and F-model pumps only) 17
2	Pump fluid thermal breakdown 27
3	Maintenance plan 36
4	Fault finding 48

Trademark credits

Fomblin® is a registered trademark of Ausimont SpA.
 Viton™ is trademark of DuPont Dow Elastomers L.L.C.
 Diffstak® is a registered trademark of Edwards.

This page has been intentionally left blank.

1 Introduction

1.1 Scope and definitions

This manual provides installation, operation and maintenance instructions for the Edwards Diffstak Mk2 diffusion pumps. You must use the Diffstak pump as specified in this manual.

Read this manual before you install and operate the pump. Important safety information is highlighted as WARNING and CAUTION instructions; you must obey these instructions. The use of WARNINGS and CAUTIONS is defined below.



WARNING

Warnings are given where failure to observe the instruction could result in injury or death to people.

CAUTION

Cautions are given where failure to observe the instruction could result in damage to the equipment, associated equipment or process.

In accordance with the recommendations of IEC1010, the following warning symbols may appear on the pump or its accessories:



Warning - refer to accompanying documentation.



Warning - risk of electric shock.



Warning - hot surfaces.

The units used throughout this manual conform to the SI international system of units of measurement.

1.2 Description

The Mk2 series of Diffstaks are compact high-performance diffusion pumps which provide exceptionally clean pumping without the use of extra traps or baffles or the need for liquid nitrogen cooling.

The basic Diffstak consists of a diffusion pump, a water-cooled baffle, a high-vacuum isolation-valve and a roughing connection all integrated into a water-cooled stainless steel casing. The high-vacuum isolation-valve is part of the inlet-flange and is configured for either manual or pneumatic operation.

Pneumatic high-vacuum isolation-valves have position indicators which indicate whether the valve is open or closed. You can connect the position indicators to your control or indicator equipment.

Four sizes of pumps are available with either a 63 mm, 100 mm, 160 mm or 250 mm diameter inlet-flange. The largest pump has a pumping speed of up to 2000 l s⁻¹. All four sizes of pump are available with unvalved collars and without the backing/roughing connection, for use in applications where high ultimate vacuum is of prime importance, or for pumping systems where a high-vacuum isolation-valve is not required.

Two unvalved versions are also available, for use in applications where the highest ultimate vacuum is required. These unvalved versions have 6 or 8 inch diameter flanges for use with copper compression gaskets. This provides simple, reliable, metal-to-metal sealing and is ideally suited to ultra-clean applications. An ultimate vacuum of less than 2×10^{-10} mbar (2×10^{-8} Pa) can be achieved with a low temperature trap.

The basic models are as follows:

- M-model pumps have a manually-operated high-vacuum isolation-valve.
- P-model pumps have a pneumatically-actuated high-vacuum isolation-valve.
- C-model pumps have an unvalved collar suitable for use with a bolted rotatable flange.
- F-model pumps are unvalved and have a copper compression gasket (ConFlat) flange.

Note: *Cryo-cooled Diffstak pumps are also available in the same four sizes as the valved and unvalved pumps. These cryo-cooled pumps have a high conductance, liquid nitrogen cooled disc located above the water-cooled baffle. The pumps are designed for use in applications which require minimum pump down times when heavy vapour loads are pumped.*

1.3 Construction

The Diffstak is a three-stage fully fractionating diffusion pump with an ejector-type third-stage. The pump-body is water-cooled and made of stainless steel with a mild-steel nickel-plated base.

The inlet-flange has an integral roughing pipeline into which a combined backing/ roughing-valve can be connected in the Diffstak 63/150, 100/300 and 160/700 pumps. The Diffstak 250/2000 is designed to use separate roughing and backing pipeline-valves. You may fit a vacuum gauge head to the coupling provided on the roughing pipeline. Housed within the inlet-flange is the low-impedance high-vacuum isolation butterfly-valve. Sectional views of the Diffstak pumps are shown in Figures 1 to 4.

Located below the valve is a baffle which consists of a water-cooled flanged cylinder with a detachable cover. The baffle also retains the jet assembly by spring pressure (except in the 250/2000 pump in which the interior is retained by a tie-rod).

The interior jet system consists of a first, second and third-stage jet assembly with fractionating tubes. Above the jet system is a detachable first-stage jet-cap. The jet system is clamped together by a central tie-rod.

The boiler is located in the base of the pump. The pump fluid is heated and vaporised by plate-type electric heater(s) (one or two, this depends on the size of the Diffstak). The boiler has a fluid filler connection and a drain-plug. The electrical supply cables from the heater are brought out to a terminal-box at the bottom of the pump for ease of connection to your electrical supply.

1.4 Principle of operation

Pump fluid is heated in the boiler to produce a vapour which passes up through the interior of the jet assembly and emerges from the jets as high-velocity vapour streams. The vapour streams condense on the cooled pump-body wall and drain into the boiler at the bottom of the pump for recirculation.

A portion of system gas which arrives at the Diffstak pump-inlet is trapped in the vapour stream from the first-stage jet. The gases are compressed and transferred to the next stage. This process is repeated through the pump jet-stages until the gases are removed by the backing pump through the cooled backing-condenser.

The guard-ring above the top-jet is designed to minimise any back-streaming of pump fluid vapour. The guard-ring traps the fluid vapour and the vapour condenses on the cooled surface of the guard-ring.

The fractionating feature of the Diffstak design provides a means of purging the fluid charge of undesirable light fractions and foreign matter and the process helps significantly towards the attainment of a low ultimate vacuum.

The ejector jet also purges the fluid of any contaminants as it returns to the boiler and at the same time ensures a high critical backing pressure even when you use low vapour pressure fluids.

Figure 1 - Sectional view of valved Diffstak 63/150 pump

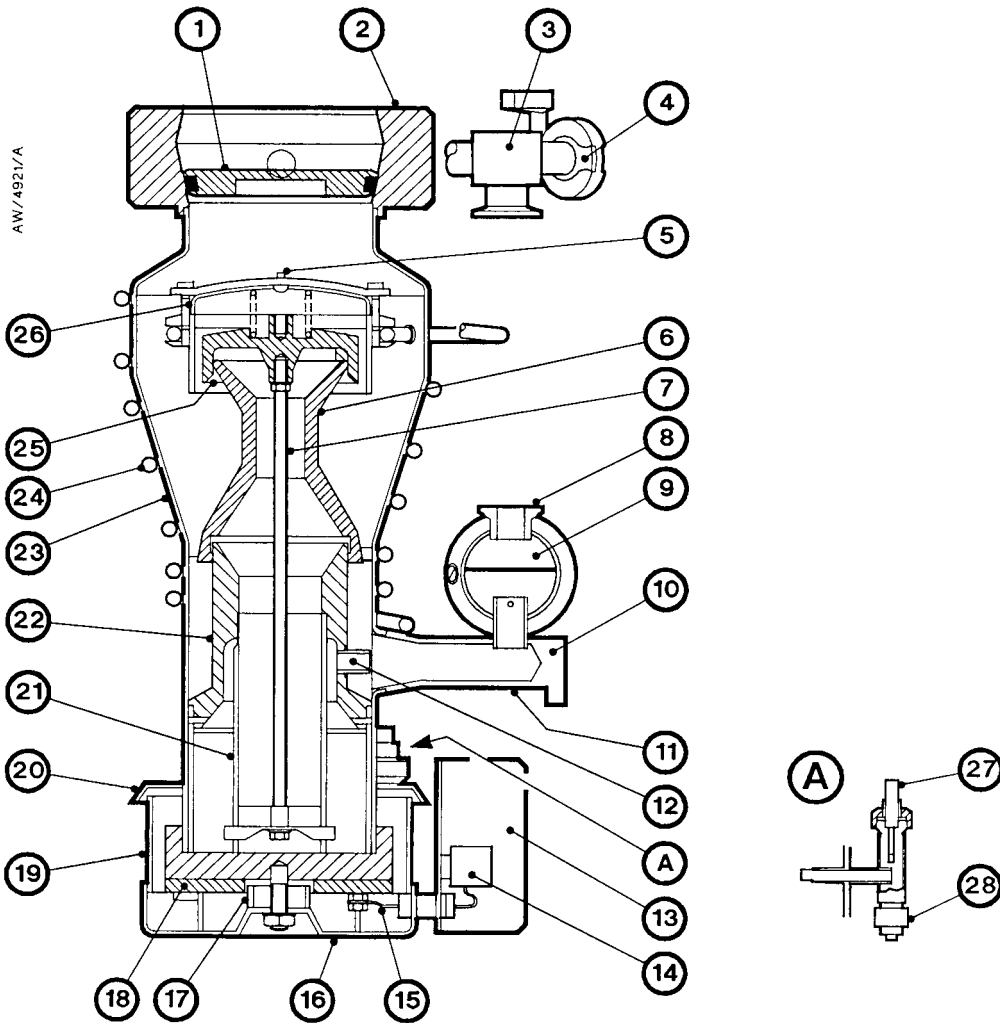

- | | | |
|--------------------------------------|-----------------------|--|
| 1. High-vacuum isolation-valve | 11. Backing spout | 22. 3rd-stage jet assembly |
| 2. Inlet-flange | 12. Ejector jet | 23. Pump-body |
| 3. Roughing connection | 13. Terminal-box | 24. Water-cooling coil |
| 4. Gauge connection (NW10) | 14. Terminal-block | 25. Top-jet assembly |
| 5. Retainer strap | 15. Electrical cables | 26. Baffle-cap |
| 6. 2nd-stage jet assembly | 16. Heater assembly | 27. Fluid filler and dipstick assembly |
| 7. Tie-rod | 17. Spacer | 28. Fluid drain |
| 8. Backing connection | 18. Heater | |
| 9. Backing condenser | 19. Pump-boiler | |
| 10. Pump-ready switch mounting plate | 20. Radiation shield | |
| | 21. Vapour-tube | |

Figure 2 - Sectional view of valved Diffstak 100/300 pump

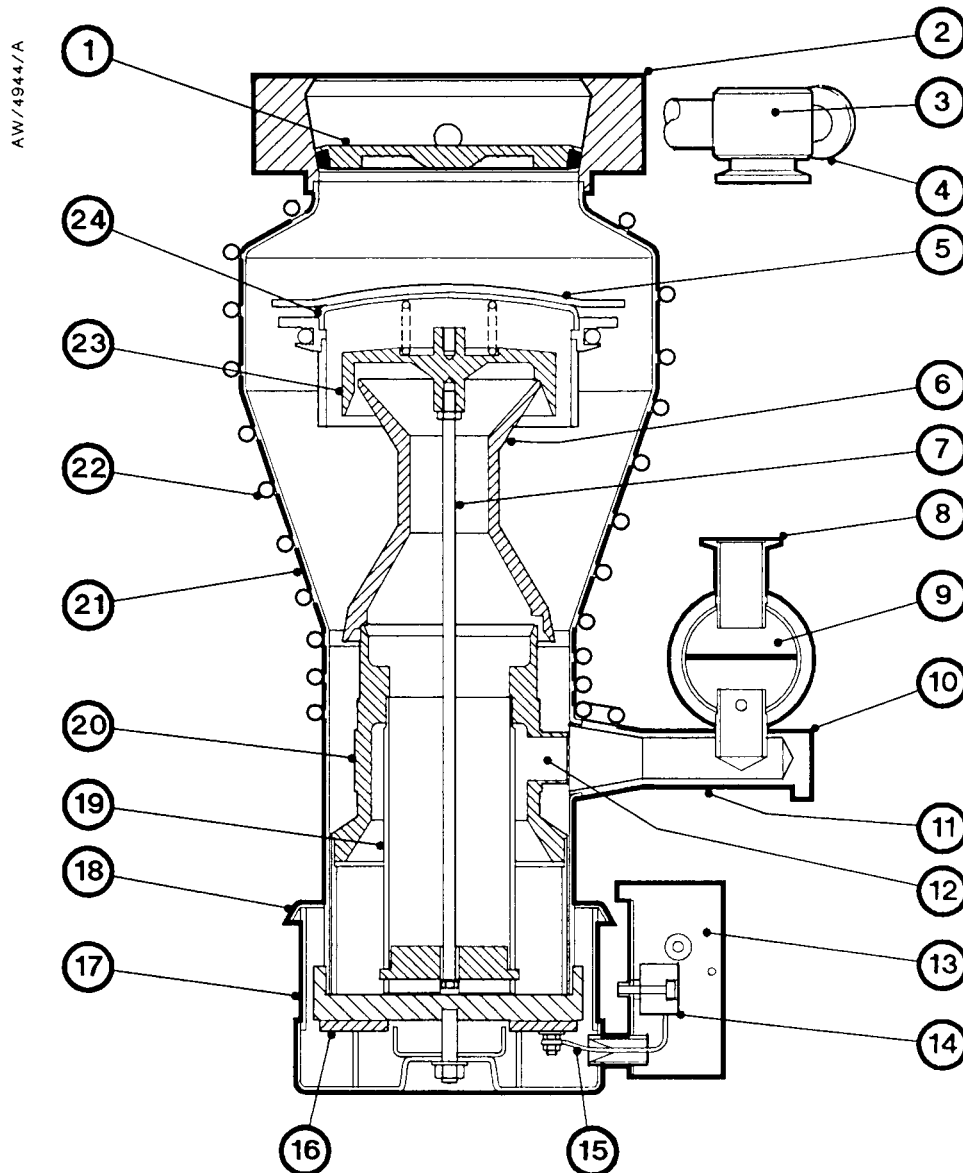

- | | | |
|--------------------------------|--------------------------------------|----------------------------|
| 1. High-vacuum isolation-valve | 10. Pump-ready switch mounting plate | 18. Radiation shield |
| 2. Inlet-flange | 11. Backing spout | 19. Vapour-tube |
| 3. Roughing connection | 12. Ejector jet | 20. 3rd-stage jet assembly |
| 4. Gauge connection | 13. Terminal-box | 21. Pump-body |
| 5. Retainer strap | 14. Terminal-block | 22. Water-cooling coil |
| 6. 2nd-stage jet assembly | 15. Electrical cables | 23. Top-jet assembly |
| 7. Tie-rod | 16. Heater | 24. Baffle-cap |
| 8. Backing connection | 17. Pump-boiler | |
| 9. Backing condenser | | |

Figure 3 - Sectional view of valved Diffstak 160/700 pump

AW/4945/B

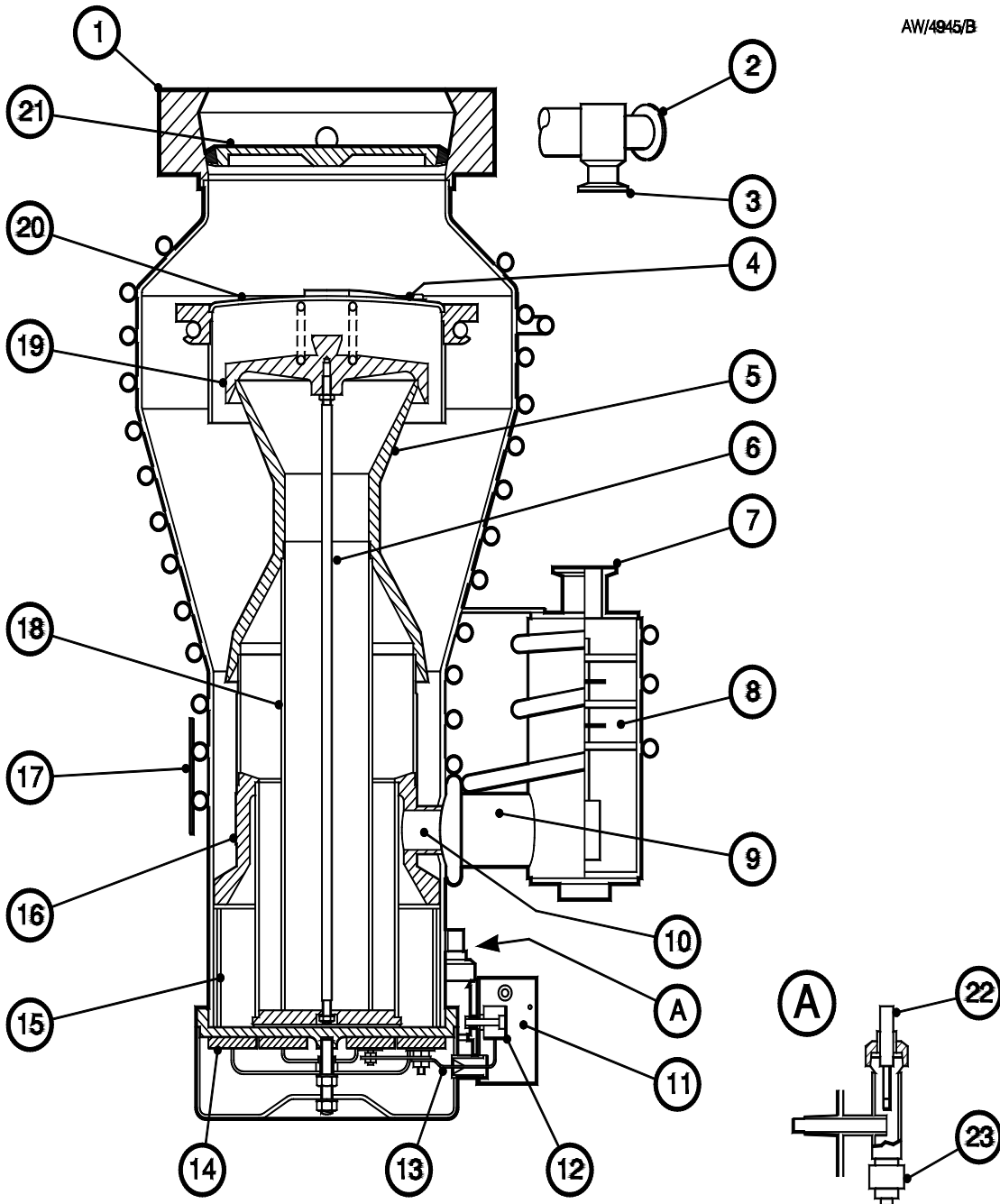

- | | | |
|---------------------------|--|--|
| 1. Inlet-flange | 10. Ejector jet | 18. Vapour-tube |
| 2. Gauge connection | 11. Terminal-box | 19. Top-jet assembly |
| 3. Roughing connection | 12. Terminal-block | 20. Baffle cap |
| 4. Retainer strap | 13. Electrical cables | 21. High-vacuum isolation-valve |
| 5. 2nd-stage jet assembly | 14. Heater | 22. Fluid filler and dipstick assembly |
| 6. Tie-rod | 15. Pump-boiler | 23. Fluid drain |
| 7. Backing connection | 16. 3rd-stage jet assembly | |
| 8. Baffle condenser | 17. Cooling-fail thermal switch mounting plate | |
| 9. Backing spout | | |

Figure 4 - Part sectional view of valved Diffstak 250/2000 pump

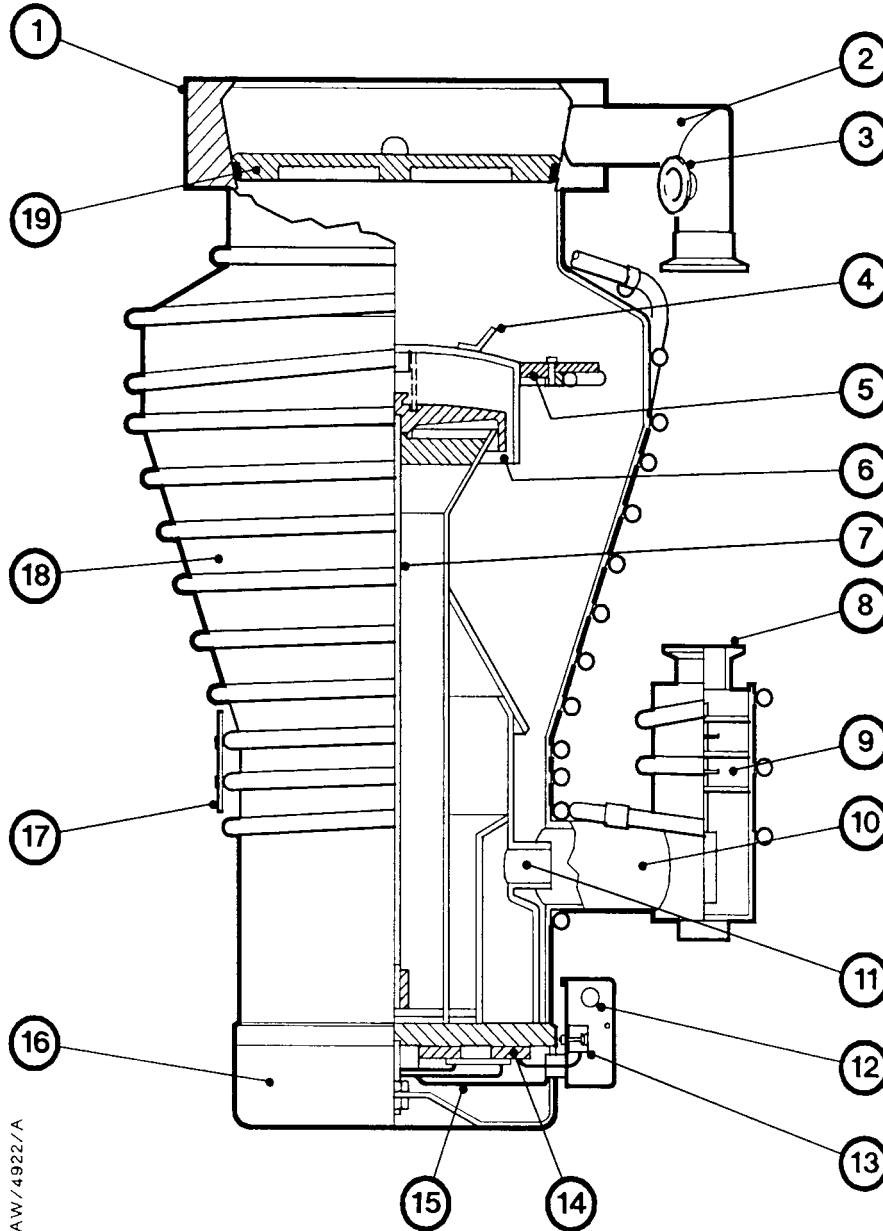

AW/4922/A

- | | |
|------------------------|--|
| 1. Inlet-flange | 11. Ejector jet |
| 2. Roughing connection | 12. Terminal-box |
| 3. Gauge connection | 13. Terminal-block |
| 4. Cool-cap | 14. Heater |
| 5. Guard-ring assembly | 15. Clamp |
| 6. Top-jet assembly | 16. Radiation shield |
| 7. Tie-rod | 17. Cooling-fail thermal-switch mounting plate |
| 8. Backing connection | 18. Pump-body |
| 9. Baffle condenser | 19. High-vacuum isolation-valve |
| 10. Backing spout | |

This page has been intentionally left blank.

2 Technical data

2.1 General

2.1.1 M-model and P-model pumps

	63/150M 63/150P	100/300M 100/300P	160/700M 160/700P	250/2000M 250/2000P
Pumping speed				
nitrogen	135 l s ⁻¹	280 l s ⁻¹	700 l s ⁻¹	2000 l s ⁻¹
hydrogen	200 l s ⁻¹	500 l s ⁻¹	1300 l s ⁻¹	3000 l s ⁻¹
Minimum backing pump displacement for maximum throughput	5 m ³ h ⁻¹	5 m ³ h ⁻¹	12 m ³ h ⁻¹	40 m ³ h ⁻¹
Recommended backing pump	RV3* or RV5	RV5 or RV8	RV12 or E2M18	E2M40
Maximum pump pressure	1300 mbar 1.3 x 10 ⁵ Pa	1300 mbar 1.3 x 10 ⁵ Pa	1300 mbar 1.3 x 10 ⁵ Pa	1300 mbar 1.3 x 10 ⁵ Pa
Recommended pump fluid	Santovac 5	Santovac 5	Santovac 5	Santovac 5
Fluid charge (dry)	60 ml	125 ml	250 ml	500 ml
Inlet connection, compatible with	ISO63	ISO100	ISO160	ISO250
Backing connection	NW10	NW25	NW25	NW40
Cooling water connection	6 mm compression couplings		10 mm compression couplings	
Minimum cooling-water flow at 20 °C	42 l h ⁻¹	60 l h ⁻¹	115 l h ⁻¹	180 l h ⁻¹
Heater power	0.45 kW	0.65 kW	1.35 kW	2.25 kW
Pneumatic connections †	6 mm couplings x 1/4 BSP male stud			
Pneumatic actuating pressure †	2.4 to 6.9 bar (35 to 100 psi, 2.4 x 10 ⁵ to 6.9 x 10 ⁵ Pa)			
Mass				
M-model	8 kg	12 kg	26 kg	59 kg
P-model	9 kg	13 kg	27 kg	60 kg
Dimensions	See Figures 5 and 6			
Position indicators †				
Maximum voltage	48 V a.c.	48 V a.c.	48 V a.c.	48 V a.c.
Maximum current	380 mA	380 mA	5 A	5 A
Enclosure protection	IP67	IP67	IP22	IP22
Mounting screw torque	0.4 Nm	0.4 Nm	-	-

* For applications where maximum throughput is not required, the RV3 can be used.

† P-model pumps only.

2.1.2 C-model and F-model pumps

	63/150C	100/300C 100/300F	160/700C 160/700F	250/2000C
Pumping speed				
nitrogen	150 l s ⁻¹	300 l s ⁻¹	760 l s ⁻¹	2130 l s ⁻¹
hydrogen	225 l s ⁻¹	535 l s ⁻¹	1410 l s ⁻¹	3200 l s ⁻¹
Minimum backing pump displacement for maximum throughput	6 m ³ h ⁻¹	6 m ³ h ⁻¹	12 m ³ h ⁻¹	40 m ³ h ⁻¹
Recommended backing pump	RV5	RV5 or RV8	RV12 or E2M18	E2M40
Maximum pump pressure	1300 mbar 1.3 x 10 ⁵ Pa	1300 mbar 1.3 x 10 ⁵ Pa	1300 mbar 1.3 x 10 ⁵ Pa	1300 mbar 1.3 x 10 ⁵ Pa
Recommended pump fluid	Santovac 5	Santovac 5	Santovac 5	Santovac 5
Fluid charge (dry)	60 ml	125 ml	250 ml	500 ml
Inlet connection, compatible with	ISO63	ISO100/6 inch	ISO160/8 inch	ISO250
Backing connection	NW10	NW25	NW25	NW40
Cooling water connection	6 mm compression couplings		10 mm compression couplings	
Minimum cooling-water flow at 20 °C	42 l h ⁻¹	60 l h ⁻¹	115 l h ⁻¹	180 l h ⁻¹
Heater power	0.45 kW	0.65 kW	1.35 kW	2.25 kW
Mass				
C-model	5 kg	9 kg	18 kg	46 kg
F-model	-	10 kg	20 kg	-
Dimensions	See Figure 7			

2.2 Pump fluid data

Note: Edwards Material Safety Data Sheets for the following fluids are available on request.

Fluid type	Critical backing pressure		Ultimate vacuum	
	mbar	Pa	mbar	Pa
Santovac 5	0.6	6.0 x 10 ¹	3 x 10 ⁻⁸	3 x 10 ⁻⁶
DC702	1.2	1.2 x 10 ²	7 x 10 ⁻⁶	7 x 10 ⁻⁴
DC704EU	0.8	8.0 x 10 ¹	7 x 10 ⁻⁸	7 x 10 ⁻⁶
DC705	0.6	6.0 x 10 ¹	3 x 10 ⁻⁸	3 x 10 ⁻⁶
Edwards L9	0.6	6.0 x 10 ¹	3 x 10 ⁻⁸	3 x 10 ⁻⁶
Apiezon C	0.7	7.0 x 10 ¹	7 x 10 ⁻⁸	7 x 10 ⁻⁶

Fluid Type	Flash point °C	Auto-ignition point °C	Molecular weight
Santovac 5	288	590	446
DC702	193	500	530
DC704EU	221	500	484
DC705	243	500	546
Edwards L9	241	370	407
Apiezon C	246	420	479

2.3 Construction materials

Interior assembly	Nickel plated mild steel and machined aluminium
Pump-body	Stainless steel unitary construction
Water-cooling coils	Stainless steel
Base	
63/150, 100/300, 250/2000	Mild steel
160/700	Stainless steel
Seals	Viton/fluoroelastomer

2.4 Item Numbers

Pump/Electrical supply	63/150	100/300	160/700	250/2000
M-model pumps				
110 to 125 V, 1-phase, 50/60 Hz	B344-31-976	B346-31-976	B348-31-976	B350-31-976
210 to 225 V, 1-phase, 50/60 Hz	B344-31-977	B346-31-977	B348-31-977	B350-31-977
230 to 250 V, 1-phase, 50/60 Hz	B344-31-978	B346-31-978	B348-31-978	B350-31-978
P-model pumps				
110 to 125 V, 1-phase, 50/60 Hz	B344-32-976	B346-32-976	B348-32-976	B350-32-976
210 to 225 V, 1-phase, 50/60 Hz	B344-32-977	B346-32-977	B348-32-977	B350-32-977
230 to 250 V, 1-phase, 50/60 Hz	B344-32-978	B346-32-978	B348-32-978	B350-32-978
C-model pumps				
110 to 125 V, 1-phase, 50/60 Hz	B344-33-976	B346-33-976	B348-33-976	B350-33-976
210 to 225 V, 1-phase, 50/60 Hz	B344-33-977	B346-33-977	B348-33-977	B350-33-977
230 to 250 V, 1-phase, 50/60 Hz	B344-33-978	B346-33-978	B348-33-978	B350-33-978
F-model pumps				
110 to 125 V, 1-phase, 50/60 Hz	-	B346-40-976	B348-40-976	-
210 to 225 V, 1-phase, 50/60 Hz	-	B346-40-977	B348-40-977	-
230 to 250 V, 1-phase, 50/60 Hz	-	B346-40-978	B348-40-978	-

Figure 5 - Dimensions of M-model Diffstak pumps (mm)

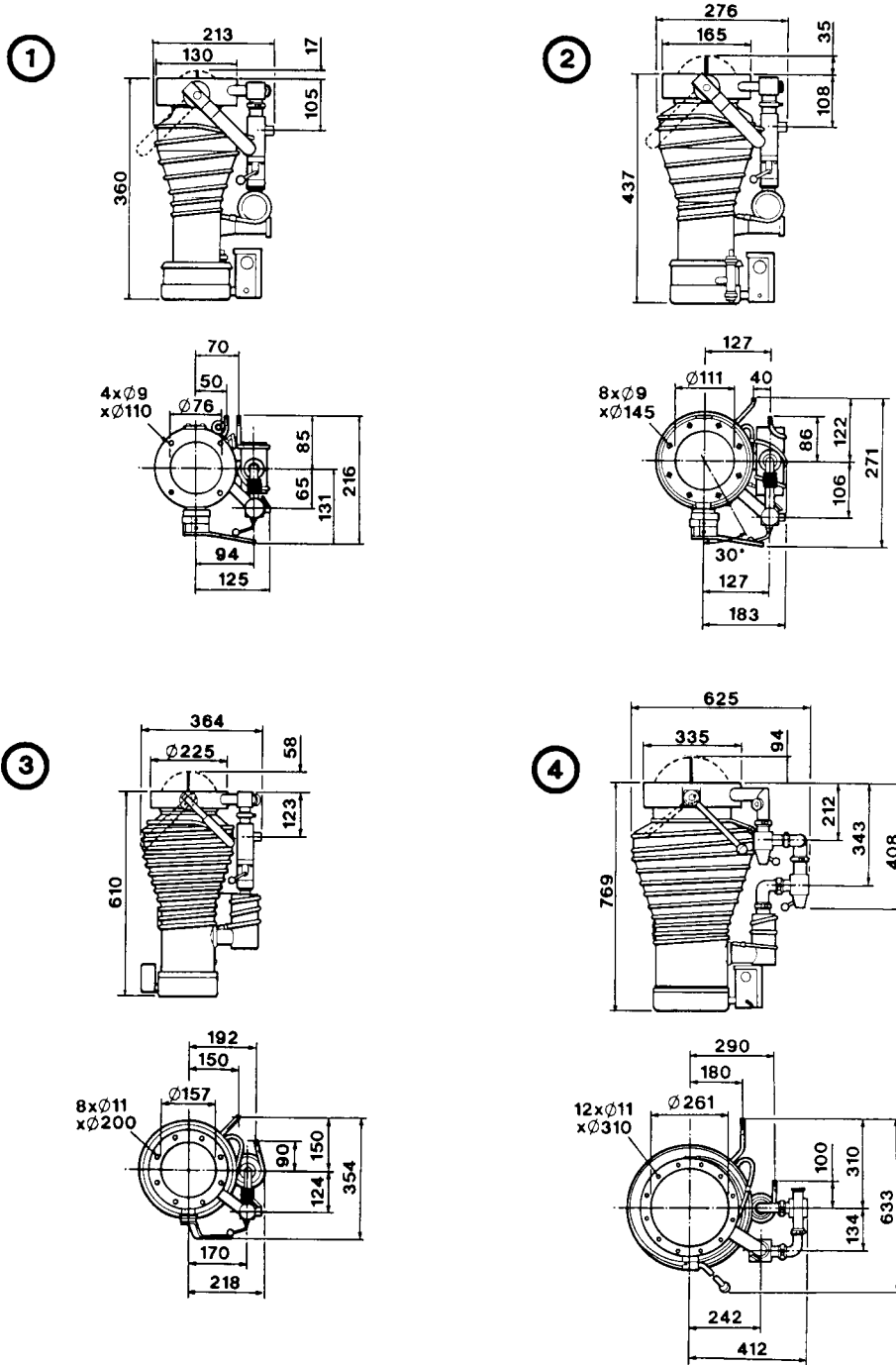

AW/1730/B

- 1. 63/150M
- 2. 100/300M

- 3. 160/700M
- 4. 250/2000M

Figure 6 - Dimensions of P-model Diffstak pumps (mm)

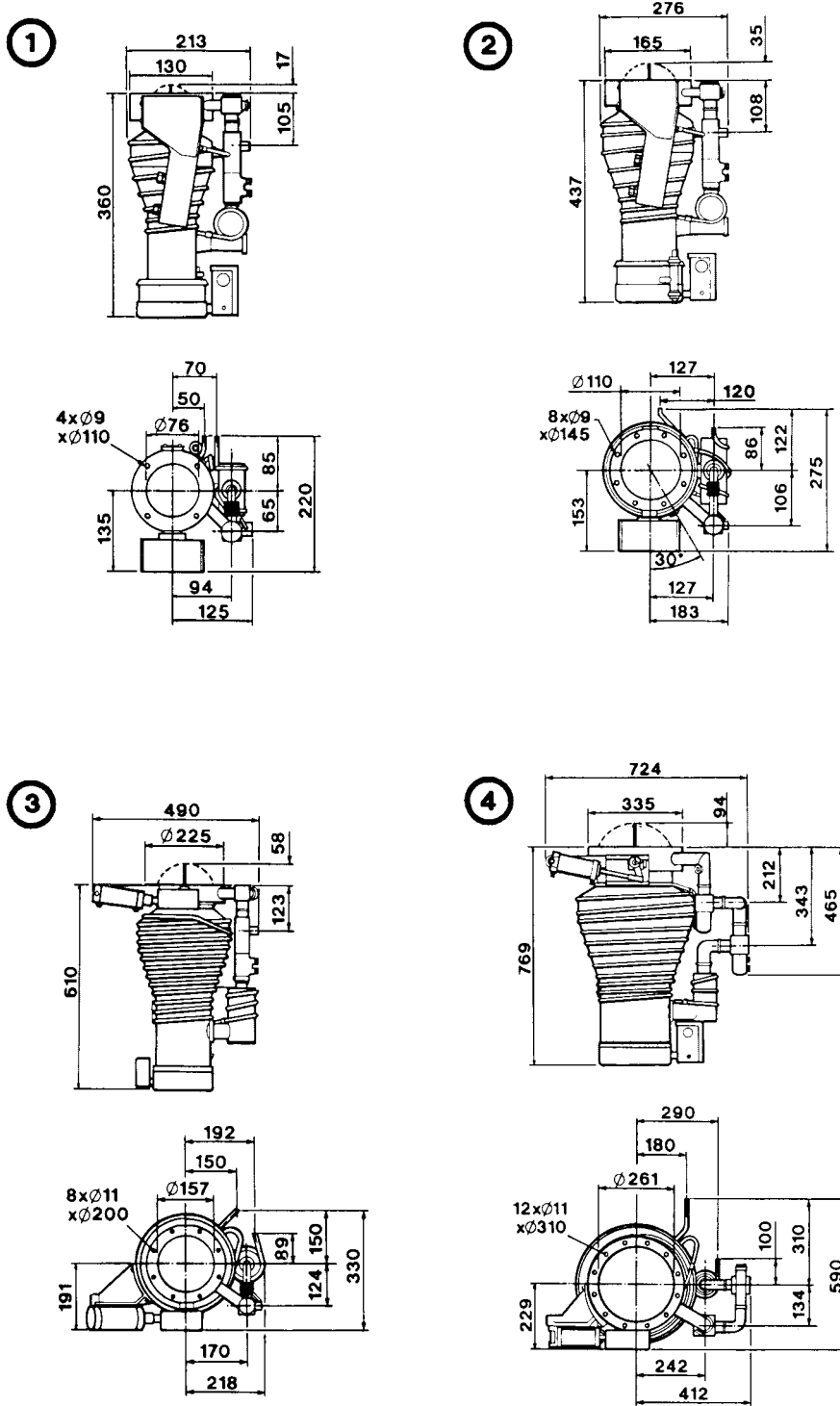

- 1. 63/150P
- 2. 100/300P

- 3. 160/700P
- 4. 250/2000P

Figure 7 - Dimensions of C-model Diffstak pumps (mm)

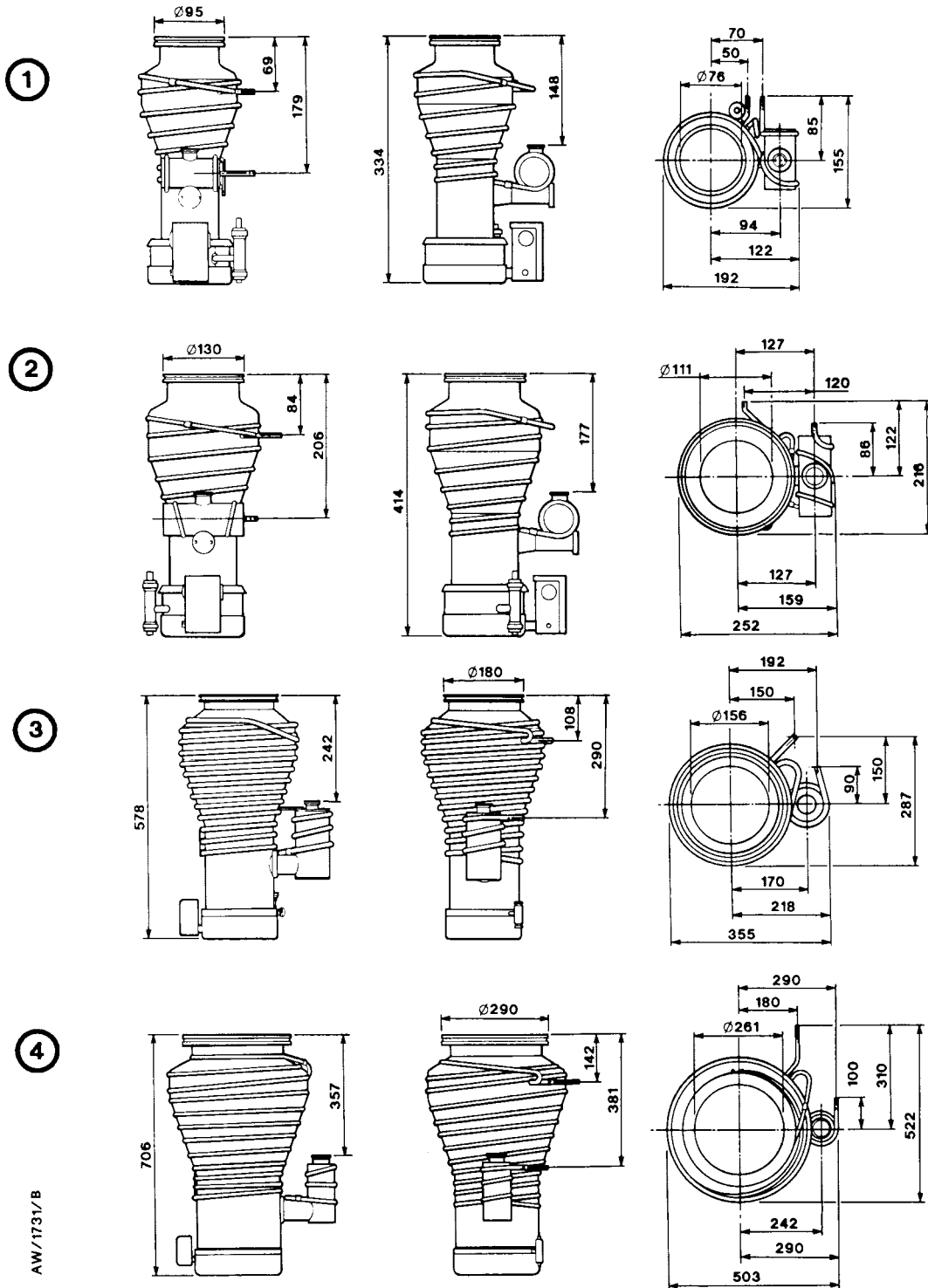

AW/1731/B

- 1. 63/150C
- 2. 100/300C

- 3. 160/700C
- 4. 250/2000C

3 Installation

3.1 Safety



WARNING

Obey the safety instructions given below and take note of appropriate precautions. If you do not, you can cause injury to people and damage to equipment.

- A suitably trained and supervised technician must install the pump.
- Isolate the other components in the vacuum system from the electrical supply before you start work.
- Use suitable lifting equipment when you move the pump.
- Ensure that the installation technician is familiar with the safety precautions which relate to the products handled by the pumping system.
- Ensure that the products handled by the pumping system are compatible with the materials of construction of the pump (see [Section 2.3](#)). If you have any doubts about the compatibility, contact your supplier or Edwards for advice.
- Do not use solvents to clean 'O' rings.

3.2 Unpack and inspect

Remove all packing material and protective covers and check the pump. If the pump is damaged, notify your supplier and the carrier in writing within three days; state the Item Number of the pump together with your order number and your supplier's invoice number. Retain all packing materials for inspection. Do not use the Diffstak if it is damaged.

Check that your package contains a fitting-kit. This kit contains some of the components that you will need to install your pump; refer to [Figures 12 and 13](#). On P-model pumps, the pneumatic connectors are supplied fitted to the connectors on the pump. If the fitting-kit or any other component is missing, notify your supplier in writing within three days.

If the pump is not to be used immediately, refit the protective covers and store the pump in suitable conditions as described in [Section 6.1](#).

Diffstak 250/2000 pumps are tested with Santovac 5 before dispatch. All internal surfaces of the Diffstak 250/2000 pump will therefore be coated with a thin film of this fluid. You must clean the pump before you fill it with a fluid other than Santovac 5 (see [Section 3.9](#)).

3.3 Locate the pump



WARNING

If the pump is not directly flange mounted to the vacuum system, you must provide additional support to ensure that the pump is stable and supported. If you do not and the pumps falls or topples, there is a risk of damage to the equipment or injury to people.

The Diffstak pump is designed to operate with the inlet-flange horizontal and at the top. Locate the pump within practical working distance from suitable electrical supplies, cooling-water and compressed-air supplies (where applicable).

3.4 Vacuum connections

Typical configurations of a vacuum system in which a Diffstak pump is installed are shown in Figures 18 and 19. The Edwards components required to connect the backing and roughing pipelines are shown in Figures 12 and 13. Some of these components are supplied in the fitting-kit; the supplied components are identified in the keys to these figures. The Item Numbers of other components are given in Section 7.

3.4.1 Diffstak inlet

The ISO compatible inlet-flanges on the valved Diffstak 63/150, 100/300 and 160/700 pumps can be bolted to any flat, unscratched surface; use the Co-Seal supplied with the Diffstak to obtain a reliable vacuum seal (see Figure 9).

Seal the inlet-flange of Diffstak 250/2000 pumps with the trapped 'O' ring supplied with the pump.

Use a rotatable-flange and Co-Seal or a Co-Seal and clamps with unvalved C-model Diffstaks (see Figure 11).

The Diffstak 100/300F and 160/700F pumps have ConFlat flanges for copper compression gaskets (see Figure 10).

Before you connect the pump-inlet, clean the flange with acetone or another suitable cleaning solution.

The inlet-flange on M-, P- and F-model pumps has a number of equally spaced fixing-holes for connection of the pump to your system. Figure 8 shows the arrangement of fixing-holes on the inlet-flange PCD (pitch circle diameter) and details of the use of bolts or studs to fit the inlet-flange.

Use the correct number and size of bolts or studs to connect the pump inlet-flange. Table 1 shows the required bolt/stud lengths, the number of flange holes in the inlet-flange and the fixing-hole PCD for the different Diffstak pump models. Fit the bolts or studs and the nuts, then tighten them alternately and evenly to a torque of 5 Nm, so that the seal is evenly loaded. If the seal is not evenly loaded, the seal may leak.

Table 1 - Inlet-flange details (M-, P- and F-model pumps only)

Pump Model	PCD Diameter (mm): Figure 8 'A'	Fixing-holes		Minimum stud length (mm): Figure 8 'B'	Minimum bolt length (mm): Figure 8 'C'
		Number of holes	Diameter (mm)		
63/150M or P	110	4	9	M8 x 85	M8 x 75
100/300M or P	145	8	9	M8 x 90	M8 x 75
100/300F	145	16	9	M8 x 65	M8 x 55
160/700M or P	200	8	11	M10 x 100	M10 x 90
160/700F	200	20	9	M8 x 70	M8 x 60
250/2000M or P	310	12	11	M10 x 120	M10 x 110

Figure 8 - Inlet-flange fitting details

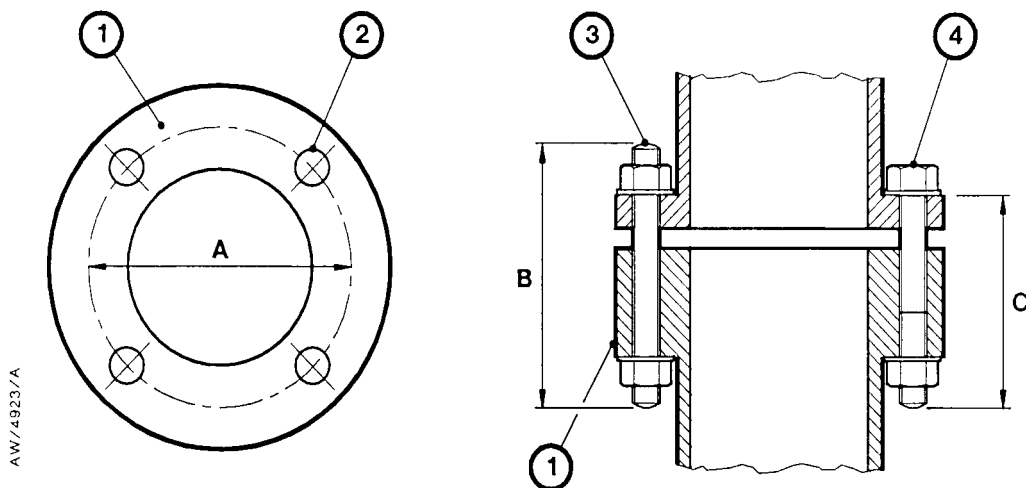

1. Inlet-flange
2. Fixing-hole

3. Stud
4. Bolt

Figure 9 - M- and P-model Diffstak inlet connection

- 1. Co-Seal
- 2. High-vacuum isolation-valve
- 3. Diffstak inlet-flange
- 4. ISO flange
- 5. Rotatable flange

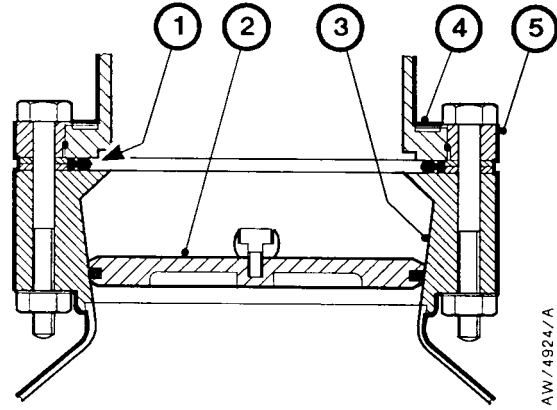

AW/4924/A

Figure 10 - F-model Diffstak inlet connection

- 1. Copper compression gasket
- 2. Diffstak inlet-flange
- 3. CF flange

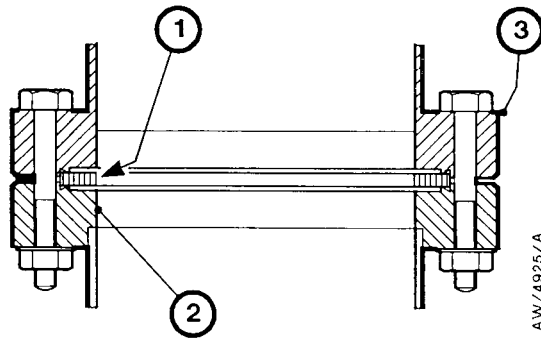

AW/4925/A

Figure 11 - C-model Diffstak inlet connection

- 1. Co-Seal
- 2. ISO tube/collar assembly
- 3. Claw clamp
- 4. Diffstak inlet-flange

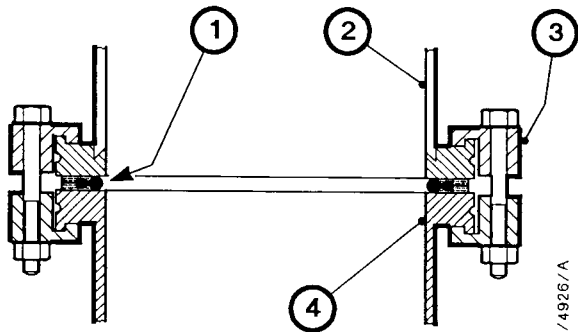

AW/4926/A

Figure 12 - Diffstak 63/150, 100/300 and 160/700 installation details

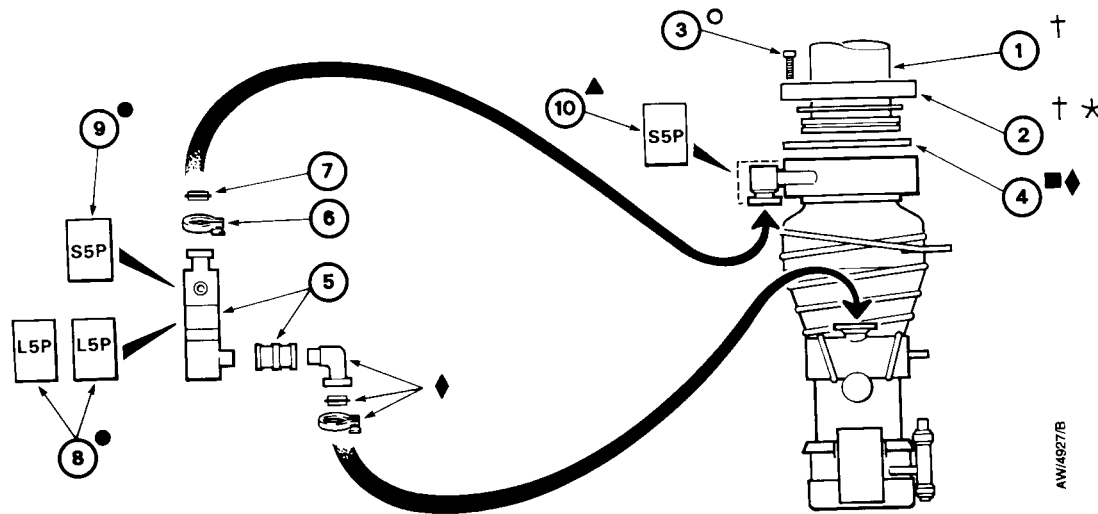

Figure key	Component	Diffstak 63/150		Diffstak 100/300		Diffstak 160/700	
		Size/type	Quantity required	Size/type	Quantity required	Size/type	Quantity required
1	ISO tube and collar assembly	ISO63	1	ISO100	1	ISO160	1
2 †★	Rotatable flange pack	ISO63	1	ISO100	1	ISO160	1
3 ○	Bolts (M- and P-model)	M8 x 75	4	M8 x 75	8	M10 x 90	8
		Bolts (F-model)	-	-	M8 x 55	16	M8 x 60
4 ■	Inlet seal	ISO63	1	ISO100	1	ISO160	1
5	BRV valve, manual	BRV10M	1	BRV25M	1	BRV25M	1
	BRV valve, pneumatic	BRV10P	1	BRV25P	1	BRV25P	1
6	Clamp	NW10	1	NW25	1	NW25	1
7	'O' ring assembly	NW10	1	NW25	1	NW25	1
8 ●	Lightweight 5-port electropneumatic control-valve	-	2	-	2	-	2
9 ●	Standard 5-port electropneumatic control-valve	-	1	-	1	-	1
10 ▲	Standard 5-port electropneumatic control-valve	-	1	-	1	-	1

† Not required for F-model pumps; use CF fittings (which must be obtained from another supplier).

★ Not required for C-model pumps; use claw clamps to bolt the pump ISO inlet-flange directly to the ISO tube and collar assembly.

○ Bolts are not available from Edwards. Bolts are not required for C-model pumps; use claw clamps to bolt the pump ISO inlet-flange directly to the ISO tube and collar assembly. Use 4 claw clamps for ISO63, ISO100 and ISO160 flanges.

■ These inlet seals are only suitable for M-, P- and C-model pumps; use CF fittings (which must be obtained from another supplier) for F-model pumps.

● Only required for pneumatically operated BRV valves; use 1 standard 5-port control-valve or 2 lightweight 5-port control-valves. If you use 2 lightweight 5-port control-valves, you can use the isolation position of the BRV valve.

▲ Only required for P-model pumps, to control the high-vacuum isolation-valve.

◆ Supplied with the pump (1 off of each component).

Figure 13 - Diffstak 250/2000 installation details

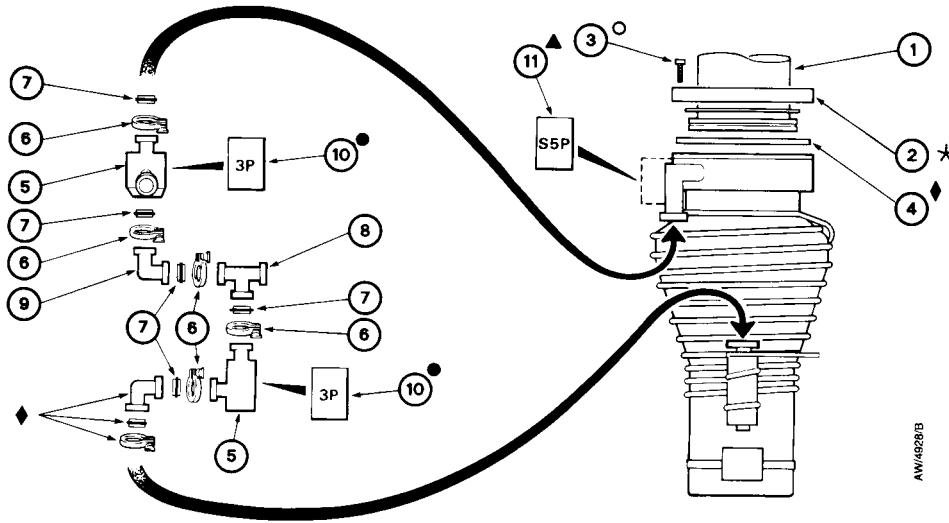

Figure key	Component	Size/type	Quantity required
1	ISO tube and collar assembly	ISO250	1
2 ★	Rotatable flange pack	ISO250	1
3 ○	Bolts (M- and P-model)	M10 x 110	12
4 ◆	Inlet seal: trapped 'O' ring	ISO250	1
5	PV40 valve, manual PV40 valve, pneumatic	PV40MK PV40MK	2 2
6	Clamp	NW40	5
7	'O' ring assembly	NW40	5
8	T-piece	NW40	1
9	Elbow	NW40	1
10 ●	3-port electropneumatic control-valve	-	2
11 ▲	Standard 5-port electropneumatic control-valve	-	1

- ★ Not required for C-model pumps; use claw clamps to bolt the pump ISO inlet-flange directly to the ISO tube and collar assembly; use 6 claw clamps for the ISO250 flange.
- Bolts are not available from Edwards. Bolts are not required for C-model pumps; use claw clamps to bolt the pump ISO inlet-flange directly to the ISO tube and collar assembly.
- Only required for pneumatically operated PVPK valves; use 1 3-port control-valve for each of the 2 PVPK valves.
- ▲ Only required for P-model pumps, to control the high-vacuum isolation-valve.
- ◆ Supplied with the pump (1 off of each component).

3.4.2 Backing and roughing connections



WARNING

Conduct the exhaust to a suitable treatment plant to prevent the discharge of dangerous gases and vapours to the surrounding atmosphere.



WARNING

If you will pump dangerous substances, you must fit a backing pressure-interlock.

Ensure that the connecting pipeline to the backing pump is as short as possible and has the maximum possible internal diameter.

You must use the correct type of exhaust extraction system for your process. The extraction system must be designed to withstand the pressure of operation and, when hazardous materials are produced or processed, must be sufficiently leaktight to contain the process materials and their by-products.

On all applications, we recommend that you fit a backing pressure-interlock to the backing pipeline, to switch off the electrical supply to the pump heater(s) if the pressure in the pipeline rises to the critical backing pressure. You must fit a backing pressure-interlock if you will pump dangerous substances. If you do not fit a pressure-interlock and the pressure in the backing pipeline rises to the critical backing pressure, fluid will backstream into the vacuum system and thermal breakdown of the pump fluid may occur. Note that if you have a suitable backing pressure gauge, you may be able to use the gauge to provide the necessary pressure signal for the pressure-interlock.

The components required to connect the backing and roughing ports on the Diffstak are shown in Figures 12 and 13. Some of these components are supplied with the pump (refer to the footnotes on Figures 12 and 13); other components can be obtained from Edwards (refer to Section 7) or from alternative suppliers.

We recommend that you use a Edwards combined roughing/backing-valve Model BRV as it is designed especially for the Diffstak 63/150, 100/300 and 160/700 pumps. You will have to use two separate valves (such as Edwards Model PV40) for selection of the roughing or backing mode of operation when you couple a Diffstak 250/2000 pump into your vacuum system.

Use the following procedure to connect the backing-flange to the backing pipeline.

1. Ensure that the backing-flange and backing pipeline sealing faces are clean and scratch-free; refinish the sealing faces if necessary.
2. Apply a light wipe of pump fluid or vacuum grease to the 'O' ring supplied.
3. Use a trapped 'O' ring and NW clamping ring (not supplied) to connect the backing-flange to the backing pipeline.

3.5 Cooling-water connections

Note: The cooling-water supply should be free from particulate contaminants to avoid blockage of the cooling coils.

Compression couplings and ferrules are included in the fitting-kit for connection of the cooling-water pipelines. Connect the water-inlet connection to the upper pipe on the Diffstak body so that the water flows through the baffle then down the Diffstak body and out through the pipe on the backing-condenser.

Maintain the water-inlet temperature as low as possible, preferably below 25 °C. Ensure the cooling-water flow is satisfactory before you switch the pump heater on.

Note: The required cooling-water flow (given in Section 2) is calculated for a 10 °C temperature rise, thus, with a high water-inlet temperature it may be necessary to increase the flow to maintain the outlet temperature below 35 °C. Do not exceed this temperature otherwise the cooling-fail thermal snap-switch (if fitted) may operate and fluid loss to the backing pipeline will increase. High cooling-water temperatures should not have any appreciable effect on Diffstak performance except to increase the vapour pressure of the fluid which will limit the ultimate vacuum that can be obtained.

3.6 Electrical connections

WARNING



Ensure that the electrical installation of the Diffstak conforms with your local and national safety requirements. The pump must be connected to a suitably fused and protected electrical supply. The pump and any thermal snap-switches fitted must be connected to a suitable earth (ground) point.

3.6.1 Connect the electrical supply to the pump

WARNING



If you connect the pump to the electrical supply when the insulation resistance of the pump heaters is less than 1 MΩ, the earth (ground) leakage current could cause injury to people.

Notes: If the pump has been transported or stored in an environment with high humidity, the pump heaters may have absorbed water. This can result in a temporary reduction of the insulation resistance of the heaters.

The electrical connections and the heaters for the Diffstak 63 and 100 pumps are manufactured to comply with the earth leakage requirements of IEC348.

Use the procedure in Steps 1 and 2 to check the insulation resistance of the heaters before you connect the electrical supply to the pump.

1. Measure the insulation resistance at 500 V d.c. between the pump-body and the heater connections in the terminal-box (see Figure 14). If the resistance is higher than 1 MΩ, continue at Step 3 below. If the resistance is 1 MΩ or lower, we recommend that you continue at Step 2 below to dry the heaters before you continue with the electrical installation.
2. To dry the heaters, use either of the procedures below:
 - Put the pump in a warm dry environment for a few days
 - Remove the heaters from the pump (see Section 5.8), place the heaters in an oven at a temperature of 180 °C for approximately 8 hours and then refit the heaters to the pump.
3. Check that the electrical supply voltage corresponds with the pump data plate.

4. Pass the supply cable through the conduit adaptor supplied with the pump (see Figure 14). If conduit is not used, fit a suitable cable restraint in place of the adaptor. We recommend that you use electrical supply cable with insulation that will withstand a temperature of 150 °C in case of accidental contact between the cable and the pump.
5. Connect the live and neutral cables to the two terminals (2, 3) coupled to the nickel heater cables. Securely connect the earth (ground) to the earth (ground) connection (5) on the terminal-box.
6. Use the remaining terminal (1) when a thermal snap-switch is fitted (see Sections 3.6.2 and 3.6.3).
7. Connect a suitable earth (ground) cable between the earth (ground) connection (5) and the cooling-fail thermal snap-switch mounting plate (refer to Figures 1 to 4).

Figure 14 - Heater electrical connections

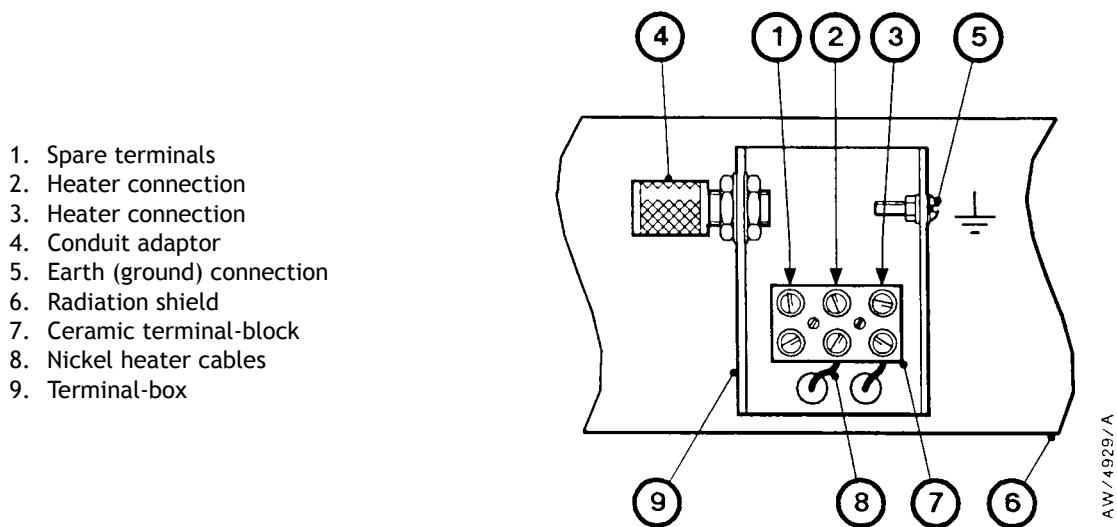

3.6.2 Connect the cooling-fail thermal snap-switch (optional)

WARNING



If you use polyphenyl ether (PPE) pump fluids in the Diffstak pump, you must fit a cooling-fail thermal snap-switch and interlock it with the pump electrical supply. If you do not, the thermal breakdown temperature of the fluid could be reached if the cooling-water supply fails. The thermal breakdown products of PPE fluids are dangerous.

This component can be supplied as an optional accessory to protect the Diffstak against damage due to failure of the cooling-water supply. If the temperature of the Diffstak increases above the normal operating level, the switch will operate to disconnect the heater from the electrical supply. The switch is preset during manufacture and automatically resets when the temperature of the pump returns to normal. The switch can be mounted on the fixing plate which is permanently attached to the cooling-coil on the Diffstak body (see Figures 1 to 4).

If you use a PPE fluid in the pump (see Table 2), you must fit the cooling-fail thermal snap-switch and interlock it with the pump heater electrical supply.

A typical electrical circuit with the thermal snap-switch connected in-series with the Diffstak heater is shown in Figure 15.

Figure 15 - Cooling-fail thermal snap-switch electrical connections

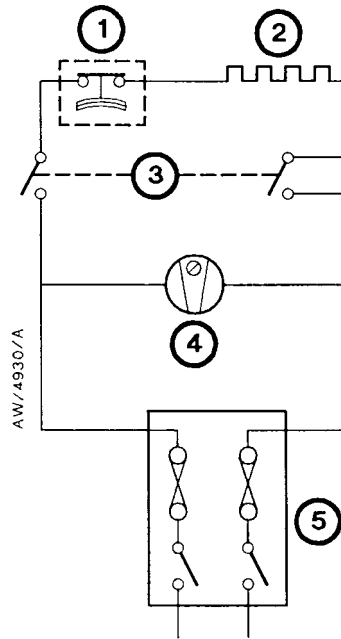

- 1. Cooling-fail thermal snap-switch (optional)
- 2. Diffstak heater
- 3. Heater switch
- 4. Rotary backing pump
- 5. Fused isolator or contactor

3.6.3 Connect the pump-ready thermal snap-switch (optional)

This switch can also be supplied as an optional accessory to indicate when the pump is in a fully operational state. The switch will operate at a preset temperature level when the jet system in the pump has reached operating temperature. The switch can be positioned at the end of the ejector-stage housing. Installation data is provided in the instruction manual supplied with the switch.

3.6.4 Connect the high-vacuum isolation-valve position indicators (63/150P and 100/300P only)

The high-vacuum isolation-valves on Diffstak 63/150P and 100/300P pumps have two position indicators. Refer to [Section 2](#) for details of the electrical specification of the position indicators and the cables. Each position indicator has a 3 m long cable connected to it; connect the two wires in each cable to your control equipment:

- The position indicator closest to the valve-plate is normally open and closes when the high-vacuum isolation-valve is closed.
- The position indicator farthest from the valve-plate (at the other end of the pneumatic cylinder) is normally open and closes when the high-vacuum isolation-valve is open.

Figure 16 - Position indicator connections (160/700P and 250/2000P only)

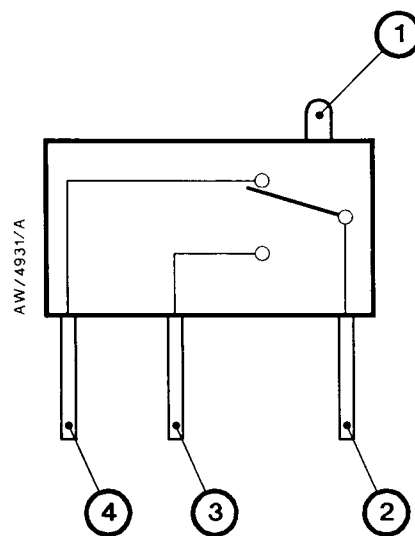

- | | |
|-------------------------|-------------------------------|
| 1. Microswitch actuator | 3. Terminal (normally open) |
| 2. Terminal (common) | 4. Terminal (normally closed) |

3.6.5 Connect the high-vacuum isolation-valve position indicators (160/700P and 250/2000P pumps only)

The high-vacuum isolation-valves on Diffstak 160/700P and 250/2000P pumps have two position indicators. Each position indicator is a microswitch, with common, normally open and normally closed terminals. One of the microswitches closes when the high-vacuum isolation-valve opens and the other microswitch closes when the high-vacuum isolation-valve closes. The locations of the microswitches on the valves are shown in [Figures 23](#) and [24](#).

Use the contacts on the microswitches to connect the microswitches to your control equipment; you can solder wires to the microswitch terminals.

If you cannot identify the terminal markings on a microswitch, refer to [Figure 16](#). As shown in [Figure 16](#): the terminal nearest the actuator is the common terminal; the terminal at the other end of the microswitch is the normally closed terminal; the terminal in the middle of the microswitch is the normally open terminal.

3.7 Connect the compressed-air supplies (P-model pumps only)



WARNING

Connect the pump to the vacuum system before you connect it to the compressed-air supply. If you do not, the isolation-valves may operate accidentally and may cause damage or injury.

The pneumatically-actuated high-vacuum isolation-valves on the Diffstak P-model pumps require a compressed-air supply of between 2.4 and 6.9 bar (35 to 100 psi, 2.4×10^5 to 6.9×10^5 Pa). A typical pneumatic circuit is shown in Figure 17.

Fit flow regulators in the exhaust-line from each end of the pneumatic actuating cylinder to limit the speed of operation otherwise damage to the high-vacuum isolation-valve or cylinder may result. Fit suitable regulators to ensure that the opening or closing times on the Diffstak 160/700 and 250/2000 pump high-vacuum isolation-valves are not less than one second.

Suitable electropneumatic control-valves are listed in Section 7 for use with the high-vacuum isolation-valve and the combined or separate roughing/backing-valves.

3.8 Leak-test the system

After you have installed the Diffstak pump, leak-test the system and seal any leaks found before you fill the pump with fluid. If you leak test the pump after you have filled it with fluid, the fluid may outgas and give false test results. Also, the pump fluid is viscous at ambient temperature and may block small leaks.

The level of leak tightness required will depend on the application of the system. You must leak-test the system to ensure the integrity of the system and its vacuum seals.

3.9 Fill the pump with fluid

3.9.1 Safety of vapour pump fluids

Vapour pump fluids are not dangerous when used in a pump that is operated correctly. But if the pump is operated incorrectly and is allowed to get to very high temperatures, the pump fluid can go through a process of thermal breakdown. The breakdown products which result can be dangerous. Table 2 gives more information about the thermal breakdown of the different vapour pump fluids. Thermal breakdown is more likely to occur if the breakdown temperature is close to the operating temperature of your pump.

Table 2 - Pump fluid thermal breakdown

Vapour pump fluid	Edwards Product	Auto-ignition Temp. °C	Breakdown Temp. °C	Thermal breakdown products	Type of danger	Possible injury
Silicone fluids (methyl phenyl siloxanes)	DC702, DC704EU, DC705	≈ 500	400	Decomposed hydrocarbons and silicon based species	Negligible	Negligible
Alkyl naphthalene fluid	Edwards L9	70	≈ 300	Naphthalene and decomposed hydrocarbons	Naphthalene is poisonous in large quantities by ingestion and skin contact	Minor (first aid may be required)
Polyphenyl ether (5-Ring)	Santovac 5	590	≈ 460 (in helium)	Phenol, benzene & phenolic materials	Phenolic materials are poisonous & caustic by ingestion and skin contact	Major (a lost time accident can occur)
Paraffinic fluids & ester fluids	Apiezon A, B, C, AP201 and AP301	≥ 305	< 300 (in air)	Decomposed hydrocarbons	Fire (Note: AP201 has a low auto-ignition temperature)	Major (a lost time accident can occur)
Perfluoro-polyether	None	None	> 260	Decomposed fluorocarbons including hydrofluoric acid	Highly aggressive materials. Poisonous and caustic by inhalation and skin contact.	Potentially fatal

3.9.2 Recommended pump fluids

WARNING



Do not use perfluoropolyether (PFPE) pump fluid in the Diffstak pump. The thermal breakdown temperature of PFPE fluids is near the operating temperature of the Diffstak pump. The thermal breakdown products of PFPE fluid are very dangerous.

WARNING



If you use polyphenyl ether (PPE) pump fluids in the Diffstak pump, you must fit a cooling-fail thermal snap-switch and interlock it with the pump electrical supply. If you do not, the thermal breakdown temperature of the fluid could be reached if the cooling-water supply fails. The thermal breakdown products of PPE fluids are dangerous.

Take note of the information given in Table 2 about the thermal breakdown temperature and decomposition products of the various pump fluids. Choose the best fluid for your application. Use Santovac 5 for the cleanest high-vacuum systems.

A cooling-fail thermal snap-switch is available as an accessory; this switch may be used to prevent the pump from overheating if the cooling-water supply fails.

Figure 17 - Schematic diagram of typical pneumatic circuit (P-model pumps only)

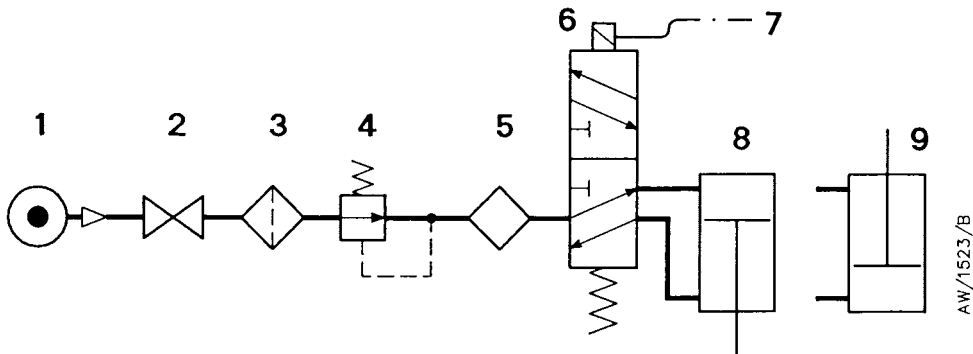

- | | |
|---|---|
| <ul style="list-style-type: none"> 1. Pneumatic supply 2. Shut-off valve 3. Filter 4. Pressure regulator 5. Lubricator 6. Standard 5-port control-valve | <ul style="list-style-type: none"> 7. Electrical connections 8. Diffstak high-vacuum isolation-valve (fail-safe closed installation) 9. Diffstak high-vacuum isolation-valve (fail-safe open installation) |
|---|---|

3.9.3 Filling procedure

Use the best fluid for your application. If the Diffstak pump already contains traces of pump fluid, you must refill it with the same type of fluid. (Note that when you receive a 250/2000 pump, all internal surfaces will be covered with a layer of Santovac 5 fluid.) If it is necessary to use a different fluid, you must clean the pump thoroughly before you fill it with a different fluid.

Fill the pump with fluid as described below.

1. Check that the drain-plug is tightened securely.
2. Pour the required amount of fluid (see [Section 2](#)) into a clean container.
3. Unscrew and remove the knurled nut on the filler connection, then remove the dipstick and the 'O' ring seal.
4. Use a funnel to fill the pump with fluid. Do not pour all of the fluid in at once as you may overfill the pump; even if the pump has been drained (see [Section 5.4](#)), up to 15% of the original fluid may remain in the pump. If you overfill the pump, you must drain off the excess fluid (see [Section 5.4](#)).
5. If the pump has been used previously, inspect the 'O' rings. Replace the 'O' rings if they are damaged, or if thermal set has taken place.
6. Refit the dipstick and 'O' ring then refit and tighten the knurled nut on the filler connection.

This page has been intentionally left blank.

4 Operation

4.1 Introduction



WARNING

If the cooling-water supply fails during operation, steam or water may be ejected from the couplings if they are disconnected. If the cooling-water supply fails, allow the pump to cool before you disconnect the couplings, or you may be injured.



WARNING

Do not touch any part of the pump when it is switched on. Avoid contact between the pump and combustible materials, plastic materials and electrical cables. Surfaces of the pump are very hot (see below) and can cause injury to people and damage to equipment:

- The temperature of the pump base can reach 400 °C
- The temperature of the pump body can reach 250 °C.

The following sections are applicable to the Diffstak 63/150, 100/300 and 160/700 pumps which are operated in conjunction with a combined backing/roughing-valve to provide a fully valved system as shown in [Figure 18](#).

The Diffstak 250/2000 pumps are similar in operation but they have separate valves in the roughing and backing pipelines (see [Figure 19](#)).

4.2 Pump start-up

The following procedure assumes that the Diffstak pump and your vacuum system are at atmospheric pressure.

1. Close the high-vacuum isolation-valve and air-admittance valve(s). Close any other openings to atmospheric pressure.
2. Select 'Backing' on the combined backing/roughing-valve.
3. Switch on the cooling-water supply to the Diffstak, then switch on the rotary backing pump.
4. When the backing pressure reaches 0.5 mbar (5×10^1 Pa) or lower, switch on the electrical supply to the Diffstak.
5. With the backing/roughing-valve in the backing mode, leave the pump a sufficient time for it to warm up. The following warm-up times are recommended for the Diffstak pumps:

Diffstak 63/150 pumps - 15 minutes	Diffstak 100/300 pumps - 20 minutes
Diffstak 160/700 pumps - 30 minutes	Diffstak 250/2000 pumps - 40 minutes
6. Check that the backing pressure is below the critical value for the pump fluid being used. Select 'Roughing' on the combined backing/roughing-valve.
7. When a system pressure of 0.3 mbar (3×10^1 Pa) or lower is reached, select 'Backing' and then open the high-vacuum isolation-valve slowly. If you open the valve too quickly, you can stall the pump.

Figure 18 - Typical pumping system: Diffstak 63/150, 100/300 and 160/700 pumps

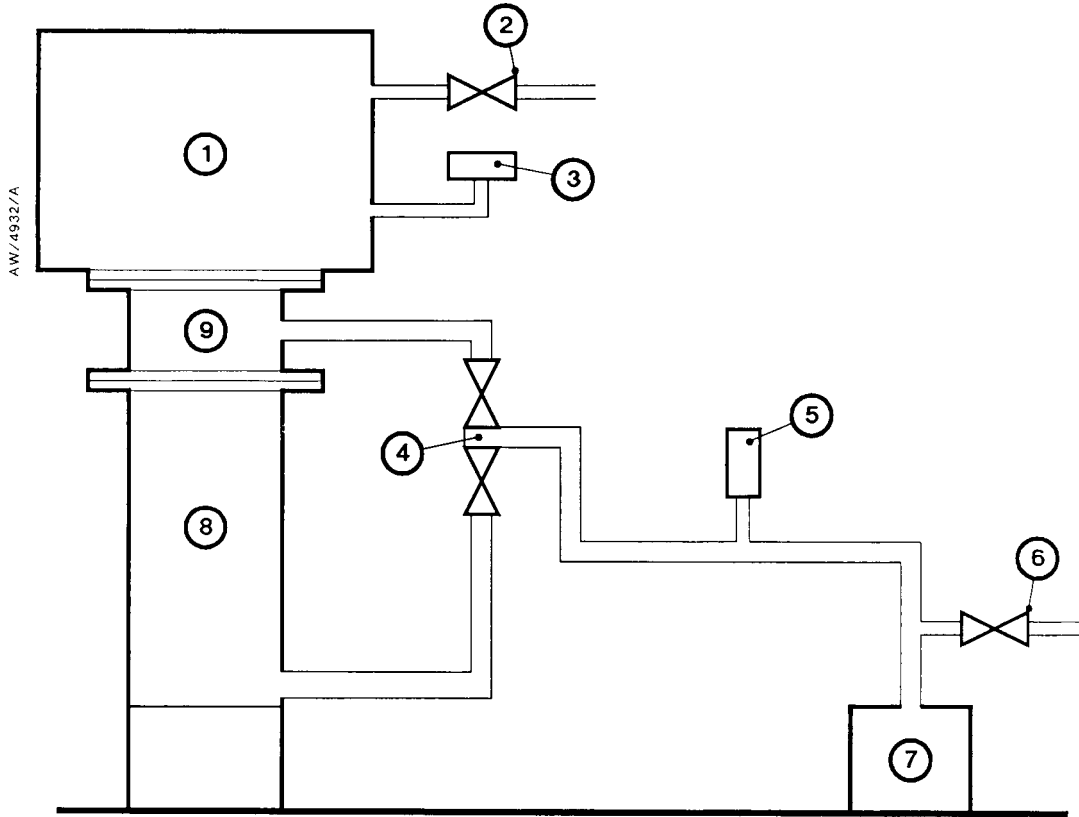

- 1. High vacuum system
- 2. Air-admittance valve
- 3. High vacuum gauge head
- 4. Combined roughing and backing-valve
- 5. Backing gauge head
- 6. Air-admittance valve
- 7. Rotary backing pump
- 8. Diffstak pump
- 9. High-vacuum isolation-valve

Figure 19 - Typical pumping system: Diffstak 250/2000 pumps

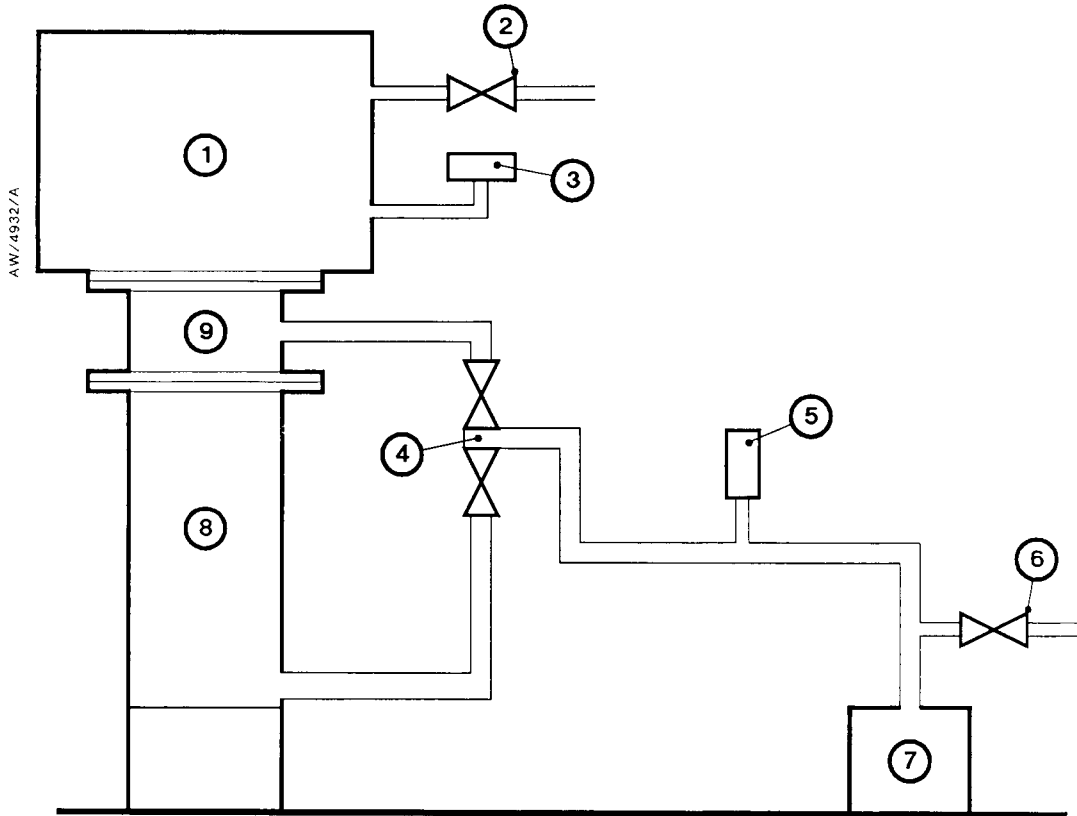

- | | |
|---------------------------|---------------------------------|
| 1. High vacuum system | 6. Air-admittance valve |
| 2. Air-admittance valve | 7. Rotary backing pump |
| 3. High vacuum gauge head | 8. Backing-valve |
| 4. Roughing-valve | 9. Diffstak pump |
| 5. Backing gauge head | 10. High-vacuum isolation-valve |

4.3 Re-admission of air to your vacuum system

1. Close the high-vacuum isolation-valve and ensure the backing/roughing-valve is in 'Backing' mode.
2. Open the chamber air-admittance valve.

4.4 Re-evacuation of your vacuum system

1. Close the chamber air-admittance valve and any other openings to atmosphere.
2. Select 'Roughing' on the combined backing/roughing-valve.
3. When a system pressure of 0.3 mbar (3×10^1 Pa) or lower is reached, select 'Backing'.
4. Open the high-vacuum isolation-valve slowly; if you open the valve too quickly, you can stall the pump.

4.5 Pump shut-down



WARNING

If the cooling-water supply fails during operation, steam or water may be ejected from the couplings if they are disconnected.

The following method of shut-down ensures that the Diffstak is left evacuated; this prevents absorption of air by the pump fluid. When you subsequently start up, evacuate the system through the roughing pipeline to a pressure of 0.3 mbar (3×10^1 Pa) or lower before you open the backing-valve.

1. Close the high-vacuum isolation-valve. Switch off the Diffstak heater and allow the pump to cool. If you do not allow the pump to cool before you admit air into the pump, on re-evacuation the pump fluid will superheat and evolve vapour which will pass into the backing pipeline.
2. Select 'Isolation' on the combined backing/roughing-valve. (If pneumatically-operated valves are fitted this will require a control circuit with two electropneumatic control-valves. Suitable control-valves are listed in [Section 7](#)).
3. Open the rotary backing pump air-admittance valve, then switch off the backing pump. Do not switch off the backing pump unless air is admitted into the backing pipeline, or backing pump oil may be drawn into the backing pipeline.
4. Turn off the cooling-water supply.

5 Maintenance

5.1 Safety



WARNING

Obey the safety instructions given below and take note of appropriate precautions. If you do not, you can cause injury to people and damage to equipment.

- A suitably trained and supervised technician must maintain the pump.
- Ensure that the maintenance technician is familiar with the safety precautions which relate to the products handled by the pumping system. Wear the appropriate safety-clothing when you come into contact with contaminated components. Dismantle and clean contaminated components inside a fume-cupboard.
- Isolate the pump from the electrical supply and your vacuum system before you start work.
- Allow the pump to cool to a safe temperature before you start work: Leave Diffstak 63/150, 100/300 and 160/700 pumps for at least 20 minutes; leave Diffstak 250/2000 pumps for at least 45 minutes. Open the pump to atmospheric pressure when it is cool.
- Do not remove the dipstick or open the drain-plug to vent the pump while the pump is operating or under vacuum.
- Use suitable lifting equipment when you move the pump.
- The pump and its fluid will be contaminated with the process chemicals that have been pumped during operation. Ensure that you take adequate precautions to protect people from the effects of dangerous substances if contamination has occurred.
- Do not touch or inhale the thermal breakdown products of fluorinated materials (for example, VITON) which may be present if the pump has been heated to 310 °C and above. These breakdown products are very dangerous. The Diffstak pump may have overheated if the pump has been misused or if it has malfunctioned. Edwards Material Safety Data Sheets for the fluorinated materials used in the Diffstak pump are available on request.
- Do not use abrasive or reactive chemical substances to clean the pump.
- Do not use solvents to clean 'O' rings. Do not reuse 'O' rings or Co-Seals if they are damaged.
- Take care to protect sealing-faces from damage.
- Leak-test the system after maintenance is complete and seal any leaks found.

5.2 Maintenance plan

The plan shown in [Table 3](#) details the maintenance operations necessary to maintain the Diffstak pump in normal use. Instructions for each operation are given in the section shown.

More frequent maintenance may be required if the pump has been used to process corrosive or abrasive gases and vapours. If necessary, adjust the maintenance plan according to your experience.

Table 3 - Maintenance plan

Operation	Frequency	Refer to Section
Check the pump fluid-level	3 Monthly (heavy duty) 6 Monthly (light duty)	5.3
Clean the cooling-coil	Yearly	5.10
Inspect the pump fluid (drain if necessary)	As required	5.4
Clean the pump	As required	5.5
Clean the radiation shield	As required	5.6
Lubricate/inspect the high-vacuum isolation-valve	As required	5.7
Renew a heater	As required	5.8
Check the heater securing nuts	As required	5.9
Adjust or replace the position indicators	As required	5.11

5.3 Check the pump fluid-level

If the Diffstak boiler operates at a higher than normal temperature, check the level of fluid in the boiler.

1. Allow the pump to cool and open it to atmospheric pressure.
2. Remove the dipstick. Remove the 'O' ring from the dipstick, then use the dipstick to check the fluid-level. The fluid-level should be visible on the dipstick and below the notch mark.
3. If the fluid-level is low, add more fluid as detailed in [Section 3.9](#).
4. Allow the fluid to drain into the boiler and check the level again. If the level is too high, drain the excess fluid (see [Section 5.4](#)).
5. Inspect the dipstick 'O' ring. Replace the 'O' ring if it is damaged or if thermal set has taken place.
6. Refit the dipstick and 'O' ring.

5.4 Inspect the pump fluid (and drain if necessary)

If the pump fails to give satisfactory performance on a leak tight system, inspect the condition of the pump fluid. Use the following procedure.

1. Allow the Diffstak pump to cool and open it to atmospheric pressure.
2. Switch on the pump heater for a maximum time of two minutes to warm the pump fluid. Do not vaporise the pump fluid.
3. Disconnect the Diffstak from the electrical supplies and detach it from your vacuum system.
4. Remove the drain-plug and allow the fluid to drain from the pump.
5. Visually check the interior of the pump.
 - If it is badly discoloured or coated with charred fluid, the pump fluid has deteriorated and must be changed; clean the pump as detailed in [Section 5.5](#).
 - If the fluid is in a satisfactory condition, refill the pump as detailed in [Section 3.9](#) and refit it to the system.

5.5 Inspect and clean the pump

5.5.1 Preparation

Note: On M- and P-model pumps, the valve-plate projects above the inlet-flange of the Diffstak in its open position. You may therefore have to close the valve before you can remove the pump from the system.

1. Allow the Diffstak to cool and open it to atmospheric pressure.
2. Drain the pump fluid as described in [Section 5.4](#).
3. Disconnect the cooling-water supply and return pipelines, the electrical supply to the heater and the backing, roughing and system connections.

5.5.2 Remove the high-vacuum isolation-valve (M-model pumps)

1. Move the valve to the fully open position.
2. Remove the screws which secure the valve-plate to the shaft and detach the valve-plate (see [Figures 20 and 21](#)).
3. Carefully withdraw the valve-shaft complete with its lever from the valve-body.

5.5.3 Remove the high-vacuum isolation-valve (P-model pumps)

1. Open the valve pneumatically and then disconnect the pneumatic pipelines from the Diffstak.
2. Remove the socket-head screws which secure the valve-plate to the shaft and detach the valve-plate.
3. Remove the valve-shaft:
 - On Diffstak 63/150P and 100/300P pumps: Detach the red safety cover from the pneumatic actuator and remove the three screws which retain the actuator to the boss on the valve-body. Carefully withdraw the valve-shaft (complete with actuator) from the valve-body (see [Figure 22](#)).
 - On Diffstak 160/700P pumps: Detach the red safety cover. Remove the two screws which retain the switch mounting bracket to the valve-body and detach the bracket. Unscrew the grub screw (M3) in the link arm and remove the pin in the cylinder. Disconnect the pneumatic cylinder. Withdraw the valve-shaft from the body (see [Figure 23](#)).
 - On Diffstak 250/2000P pumps: Detach the red safety cover. Remove the two screws which retain the switch mounting bracket and remove the circlip from the cylinder pivot-pin. Withdraw the valve-shaft from the body complete with the pneumatic cylinder and linkage (see [Figure 24](#)).

5.5.4 Dismantle the pump

1. On Diffstak 63/150 pumps, slacken the single screw which retains the baffle-cap strap; on other pumps, slacken the two screws which retain the baffle-cap strap. Rotate the strap to release it.
2. Withdraw the baffle-cap from the Diffstak; use the grips provided to ease the baffle-cap through the bore of the valve-body.
3. Remove the interior jet assembly:
 - On Diffstak 63/150, 100/300 and 160/700 pumps: Remove the spring from the first-stage jet-cap then insert the extractor tool in the threaded hole in the boss (grip the boss on the Diffstak 160/700 jet-cap) and lift out the complete interior jet assembly from the body.
 - On Diffstak 250/2000 pumps: Unscrew the top-jet cap then remove the second and third-stage sections separately.

Figure 20 - High-vacuum isolation-valve: Diffstak 63/150, 100/300 and 160/700 pumps

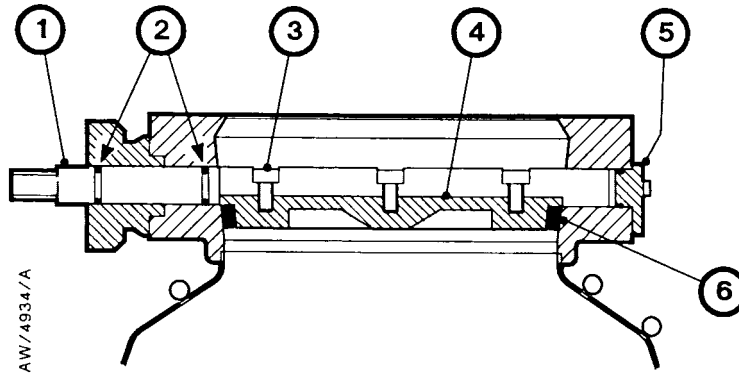

- | | |
|--------------------------|---------------------|
| 1. Valve-shaft | 4. Valve-plate |
| 2. Valve-shaft 'O' rings | 5. Blanking-plate |
| 3. Screw (3 off) | 6. Valve-plate seal |

Figure 21 - High-vacuum isolation-valve: Diffstak 250/2000 pumps

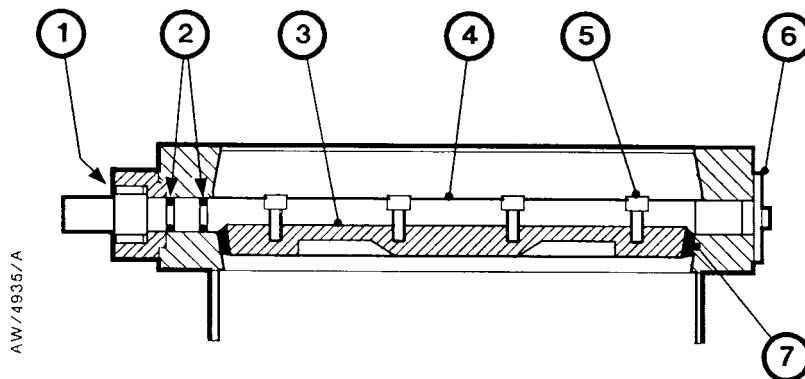

- | | |
|--------------------------|---------------------|
| 1. Needle roller-bearing | 5. Screw (4 off) |
| 2. Valve-shaft 'O' rings | 6. Blanking-plate |
| 3. Valve-plate | 7. Valve-plate seal |
| 4. Valve-shaft | |

5.5.5 Inspect and clean the interior



WARNING

Remove all traces of the cleaning solution before you operate the pump.

When you clean the pump, choose the cleaning solution to suit the type of pump fluid that has been used. The jet assembly can be vapour de-greased.

1. Inspect the pump interior. If there is a solid deposit of pump fluid around the base, do not attempt to remove the deposit mechanically as this is likely to damage the pump; instead, attempt to remove the deposit with an ultrasonic cleaning bath.
2. Wash the interior of the pump and the pump interior components with the selected cleaning solution.
3. Wash again with acetone to remove all traces of the solution. Bake to 77 °C to remove the acetone. Alternatively, pass warm air over the components and the pump interior.
4. Check that all sealing-faces are scratch-free. Refinish surfaces that are scratched.

5.5.6 Reassemble the pump

1. Insert the jet assembly in the pump-body and position it on the base; align the ejector jet with the backing tube and the slot in the base of the jet assembly with the drain-tube extension.
2. Position the spring on the top-jet cap.
3. Ease the water-cooled baffle-cap through the valve bore to insert it in the pump. Assemble the baffle-cap and the retaining strap, then secure the strap:
 - On Diffstak 63/150 pumps: the baffle-cap strap is secured by one screw at the centre of the strap.
 - On Diffstak 100/300, 160/700 and 250/2000 pumps: the baffle-cap strap is secured by two screws.
4. To refit a manually-operated high-vacuum isolation-valve, carefully insert the valve-shaft in the valve-body and fit the valve-plate and the screws. Do not tighten the screws fully (lubricate seals and bearings as described in [Section 5.7](#)). Open and close the valve slowly a few times to ensure the valve-plate is centrally positioned on the shaft, then, with the valve in the fully closed position, tighten the screws securely.

(Continued on [page 42](#))

Figure 22 - Pneumatic actuator for the isolation-valve: Diffstak 63/150P and 100/300P pumps

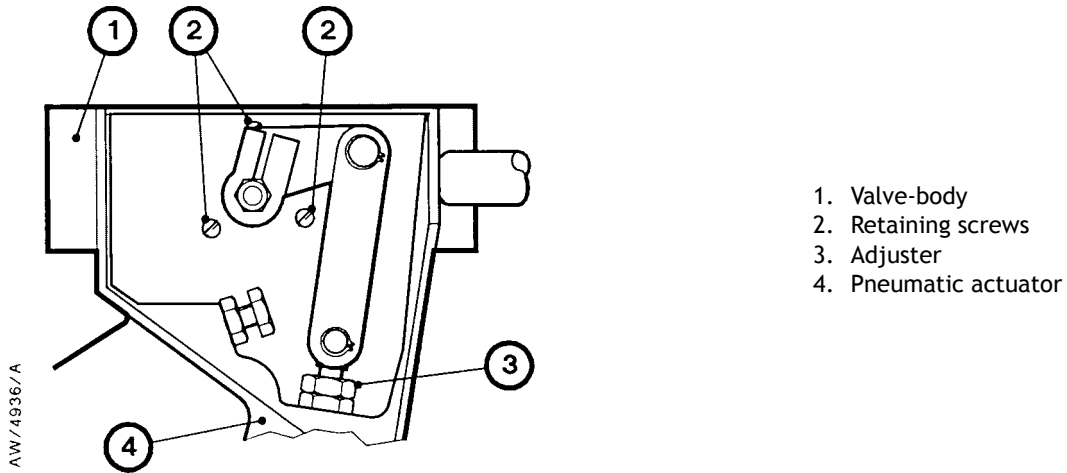

- 1. Valve-body
- 2. Retaining screws
- 3. Adjuster
- 4. Pneumatic actuator

Figure 23 - Pneumatic actuator for the isolation-valve: Diffstak 160/700P pumps

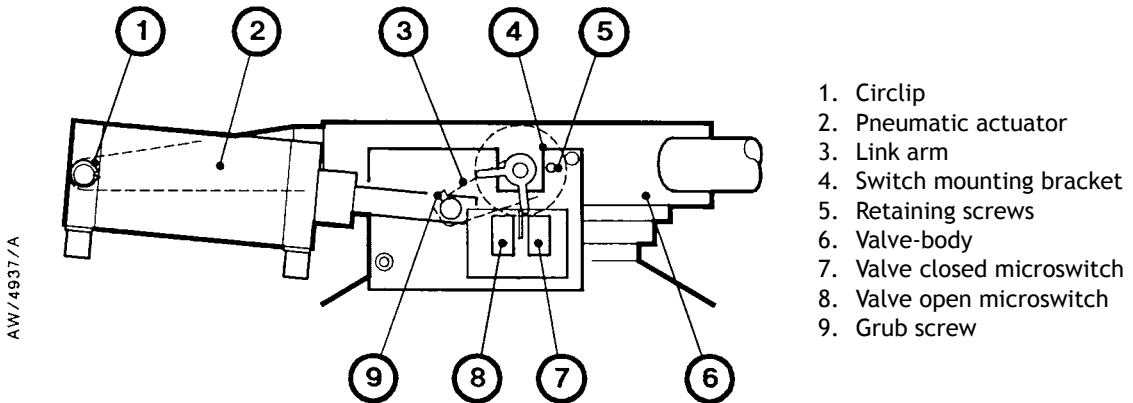

- 1. Circlip
- 2. Pneumatic actuator
- 3. Link arm
- 4. Switch mounting bracket
- 5. Retaining screws
- 6. Valve-body
- 7. Valve closed microswitch
- 8. Valve open microswitch
- 9. Grub screw

Figure 24 - Pneumatic actuator for the isolation-valve: Diffstak 250/2000P pumps

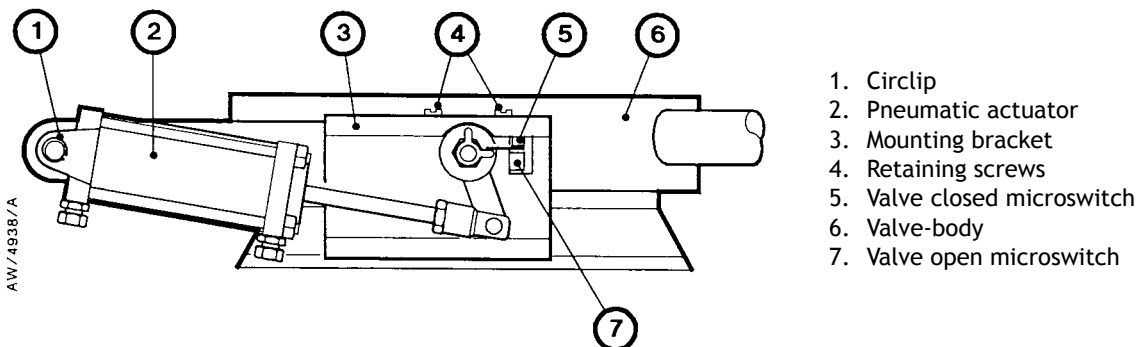

- 1. Circlip
- 2. Pneumatic actuator
- 3. Mounting bracket
- 4. Retaining screws
- 5. Valve closed microswitch
- 6. Valve-body
- 7. Valve open microswitch

5. To refit a pneumatically-actuated valve:
 - On Diffstak 63/150P and 100/300P pumps: Assemble as in step 4. Secure the actuator to the boss on the valve-body with the retaining screws. Fit the safety cover.
 - On Diffstak 160/700P pumps: Assemble as in step 4. Connect the pneumatic cylinder to the link arm and secure the pin with the grub screw. Fit the switch mounting bracket and secure with the retaining screws; ensure that the microswitch operating lever is positioned correctly. Fit the safety cover.
 - On Diffstak 250/2000P pumps: Assemble as in step 4. Connect the pneumatic cylinder at the pivot-pin mounting and secure the microswitch mounting bracket to the boss on the valve-body; ensure that the microswitch operating lever is positioned correctly. Fit the safety cover.
6. Refit the baffle.
7. Inspect all of the 'O' rings; replace any that are damaged or that have undergone thermal set. Use a dry, lint-free cloth or paper to clean the undamaged 'O' rings. Ensure that all 'O' rings are dust-free before reassembly.
8. Reconnect the Diffstak pump to your vacuum system. Fill the pump with fluid as detailed in [Section 3.9](#).
9. Reconnect the electrical supply and the cooling-water pipelines. For P-model pumps, reconnect the pneumatic pipelines.
10. Test the installation to ensure that the Diffstak pump operates correctly.

5.6 Clean the radiation shield

Keep the radiation shield which surrounds the Diffstak boiler clean to maintain thermal efficiency.

To clean the external surface of the radiation shield:

1. Isolate the pump from the electrical supply.
2. Allow the pump to cool:
 - On Diffstak 250/2000 pumps: Allow the pump to cool for at least 45 minutes.
 - On Diffstak 63/150, 100/300 and 160/700 pumps: Allow the pump to cool for at least 20 minutes.
3. Wipe the radiation shield with a soft cloth (and use a suitable cleaning solution if necessary).

If you then need to clean the internal surface of the radiation shield:

1. Remove the heater assembly.
2. Remove the radiation shield.
3. Clean the radiation shield.
4. Refit the radiation shield and then the heater assembly.

5.7 Lubricate/inspect the high-vacuum isolation-valve (M- and P-model pumps)

If the high-vacuum isolation-valve is difficult to operate (that is, it sticks because it has been left in the closed position for long periods, or it is stiff), we recommend that you lightly lubricate the valve-plate seal with Fomblin RT15 grease. If you think that the valve-plate seal or shaft 'O' ring seals may be defective, inspect and replace them if necessary.

To inspect/lubricate the high-vacuum isolation-valve, use the procedure below.

1. Allow the Diffstak to cool and open it to atmospheric pressure.
2. Drain the pump fluid as detailed in [Section 5.4](#). Disconnect the cooling-water supply and return pipelines, the electrical supply to the heater and the backing, roughing and system connections.
3. Remove the pump from the system and remove the valve-plate from the shaft (refer to [Sections 5.5.2](#) and [Section 5.5.3](#)).
4. Examine the valve-plate seal and the 'O' rings on the valve-shaft. If they are worn or damaged, use new replacement parts (see [Section 7](#)). Lightly lubricate replacement 'O' rings and the valve-shaft roller-bearings with pump fluid prior to reassembly. Lightly lubricate replacement valve-plate seals with Fomblin RT15 grease.
5. Reassemble the valve and refit the pump as detailed in [Section 5.5.6](#).

5.8 Replace the pump heater(s)

5.8.1 Diffstak 63/150 and 100/300 pumps

Use the following procedure to replace a heater on Diffstak 63/150 and 100/300 pumps:

1. Isolate the Diffstak from the electrical supply.
2. Refer to [Figure 25](#). Remove the retaining screws and detach the cover from the terminal-box (1). Disconnect the incoming electrical supply cables and the earth (ground) cable at the terminal-block.
3. Remove the nut (3) from the radiation shield/heater assembly securing stud and lower the complete radiation shield (4) and heater assembly. Disconnect the electrical connections at the heater and remove the heater.
4. Replace the defective heater(s) (2) and reconnect the heater electrical supply cables to the terminal-block.
5. Coat the thread of the radiation shield/heater assembly securing stud with an anti-seize compound and refit the radiation shield/heater assembly in position; make sure that the terminal-box (1) is correctly located relative to the backing tube. Secure with the nut (3) and tighten to a torque in the range of 8 to 10 Nm.
6. Reconnect the electrical supply cables to the terminal-block. Reconnect the earth (ground) cable to the earthing (grounding) screw. Refit the cover to the terminal-box (1).

Figure 25 - Heater assembly: Diffstak 63/150 and 100/300 pumps

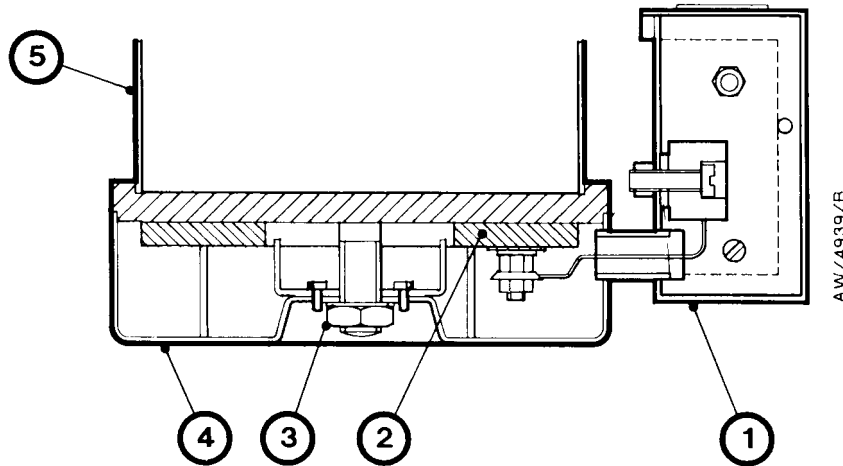

- | | |
|-----------------|---------------------|
| 1. Terminal-box | 4. Radiation shield |
| 2. Heater | 5. Pump boiler |
| 3. Nut | |

5.8.2 Diffstak 160/700 and 250/2000 pumps

Use the following procedure to replace a heater on Diffstak 160/700 and 250/2000 pumps:

1. Isolate the Diffstak from the electrical supply.
2. Refer to [Figure 26](#). Remove the retaining screws and detach the cover from the terminal-box (1). Disconnect the incoming supply cables at the terminal-block. Disconnect the earth (ground) cable. Disconnect the two cables to the heaters.
3. Remove the nut (4) from the radiation shield/heater assembly securing stud to release the radiation shield (5) together with the terminal-block. Ensure that the nickel heater cables feed freely through the insulators without damage to either the cables or the insulators.
4. Remove the nut (3) which retains the clamp plates (6) and the two heaters (2). Remove the parallel links which connect the heater terminals.
5. Replace the defective heater(s) (2), and reassemble; make sure that the two heaters are securely connected in parallel and that there is sufficient length of cable connected to the heaters to feed through the insulators and reach the terminal-block.
6. Coat the thread of the radiation shield/heater assembly securing stud with anti-seize compound and assemble the heaters (2) and clamp plates (6); refit the nut (3) and tighten to a torque in the range of 10 to 12 Nm. Ensure that the heater assembly is in the correct orientation so that when the radiation shield (5) and terminal-box are reassembled, the cables from the heaters can be fed through to the connector in the terminal-box. The terminal-box must be correctly located relative to the backing tube.
7. Refit the radiation shield (5) and terminal-box in position and secure with the second nut (4); tighten the nut to a torque in the range of 10 to 12 Nm.
8. Reconnect the electrical supply cables and the earth (ground) connection. Refit the cover to the terminal-box (1).

Figure 26 - Heater assembly: Diffstak 160/700 and 250/2000 pumps

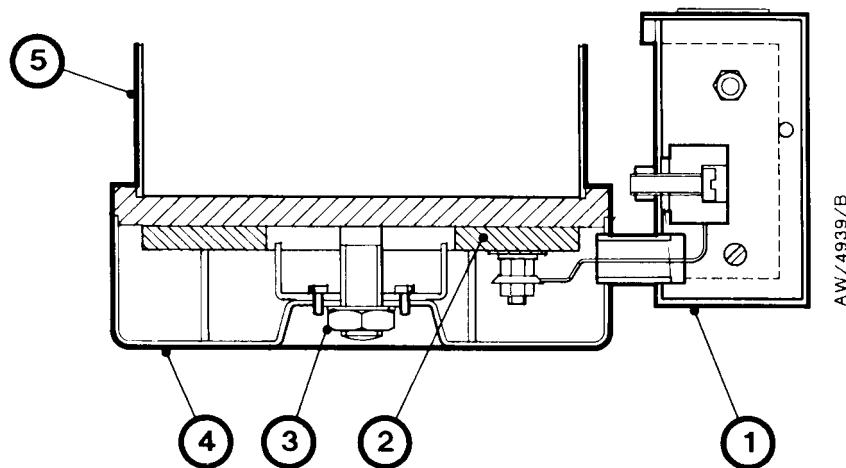

- | | |
|-----------------|---------------------|
| 1. Terminal-box | 5. Radiation shield |
| 2. Heater | 6. Clamp plates |
| 3. Nut | 7. Pump boiler |
| 4. Nut | |

5.9 Check the heater securing nuts

If the pump is regularly heated up and cooled down, check the tightness of the heater securing nut(s) frequently. Refer to [Section 5.8](#) to tighten these nuts.

5.10 Clean the cooling-coil

The cooling-coil should be cleaned at least once a year, and more regularly if the water supply has a high calcium content.

To clean the cooling-coil, flush with a suitable descaler. For example, use a 15% hydrochloric acid solution for decalcification, then use a 5% sodium carbonate solution for neutralization.

5.11 Adjust or replace the position indicators

5.11.1 Adjust the position indicators

If the position indicators are loose, use the following procedure to adjust them.

1. Refer to [Figure 27](#). Loosen the clamp screw (7) on the valve closed position indicator (1).
2. Slide the position indicator in the dovetail groove (3) until the gap (2) between the position indicator and the valve actuator is correct.
3. Apply a suitable thread sealant (such as Loctite 222e) to the clamp screw (7) and tighten the clamp screw to a torque of 0.4 Nm.
4. Repeat Steps 1 to 3 above to adjust the gap (5) between the valve open position indicator (6) and the end of the pneumatic actuator.

5.11.2 Replace the position indicators

If the position indicators are damaged, you must replace them; refer to [Section 7.2](#) for the Item Numbers of the position indicator spares kits. Use the following procedure to replace the position sensors.

1. Refer to [Figure 27](#). Loosen the clamp screw (7) on the valve open position indicator (6).
2. Slide the position indicator down the dovetail groove (3) and out of the cylinder.
3. Loosen the clamp screw (7) on the valve closed position indicator (1).
4. Slide the position indicator down the dovetail groove (3) and out of the cylinder.
5. Ensure that the dovetail groove is clean, then slide the new valve closed position indicator (1) into the dovetail groove (3); ensure that the position indicator is oriented correctly, as shown in [Figure 27](#).
6. Adjust the position indicator until the gap (2) between the position indicator and the valve actuator is correct.
7. Apply a suitable thread sealant (such as Loctite 222e) to the clamp screw (7) and tighten the clamp screw to a torque of 0.4 Nm.
8. Slide the new valve open position indicator (6) into the dovetail groove; ensure that the position indicator is oriented correctly, as shown in [Figure 27](#).
9. Adjust the position indicator until the gap (5) between the position indicator and the end of the pneumatic actuator is correct.
10. Apply a suitable thread sealant (such as Loctite 222e) to the clamp screw (7) and tighten the clamp screw to a torque of 0.4 Nm.

Figure 27 - Adjust or replace the position indicators

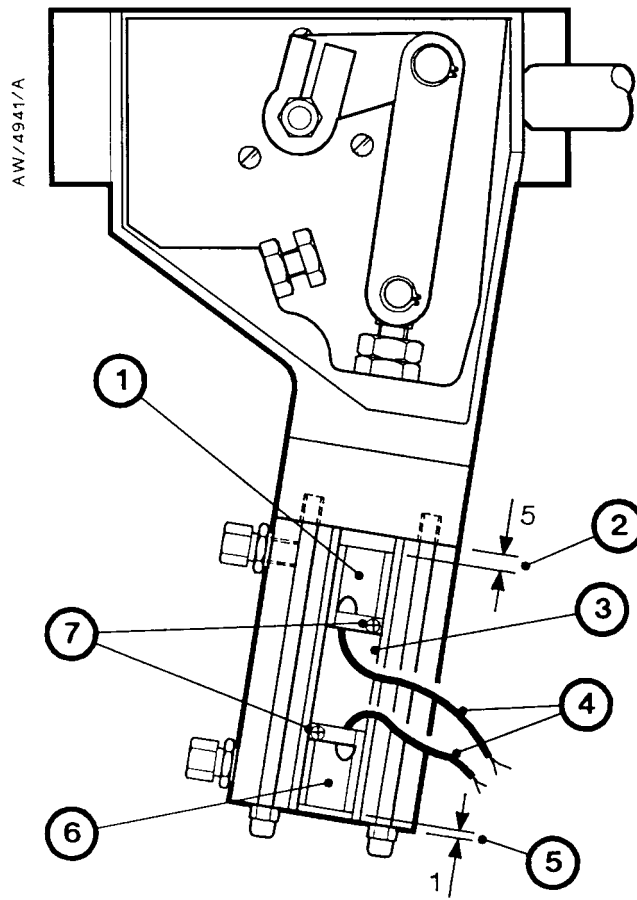

- | | |
|--------------------------------------|------------------------------------|
| 1. Position indicator (valve closed) | 5. Gap |
| 2. Gap | 6. Position indicator (valve open) |
| 3. Dovetail groove | 7. Clamp screw |
| 4. Position indicator wires | |

5.12 Fault finding

Table 4 - Fault finding

Symptom	Check	Action
Poor ultimate pressure	<p>Is there a leak in the system, virtual or real ?</p> <p>Is the system dirty ?</p> <p>Is the pump fluid contaminated ?</p> <p>Is the heat input low or high ?</p> <p>Is there inadequate cooling ?</p> <p>Is the backing pressure high ?</p> <p>Is your vacuum gauge incorrectly calibrated ?</p>	<p>Locate and seal the leak.</p> <p>Clean the system.</p> <p>Inspect the fluid and replace if necessary.</p> <p>Check the supply voltage. Check the heater for power rating, electrical continuity, burnt out element, poor thermal contact.</p> <p>Check the cooling-water pressure. Check the cooling-coils for obstructions and back pressure.</p> <p>Check for a leak in the backing pipeline, poor rotary pump performance, thermal breakdown of the pump fluid.</p> <p>Check and rectify.</p>
Inlet pressure surges	<p>Is the heater input incorrect ?</p> <p>Is the pump fluid outgassing ?</p> <p>Is there a leak in the system ahead of the inlet to the Diffstak ?</p> <p>Is there trapped volume in the system ?</p> <p>Are the 'O' ring seals excessively lubricated ?</p> <p>Is there excessive fluid charge ?</p>	<p>Check and rectify.</p> <p>Inspect the pump fluid and replace if necessary.</p> <p>Check and rectify.</p> <p>Check and rectify.</p> <p>Check and rectify.</p> <p>Drain off, as necessary.</p>

6 Storage and disposal

6.1 Storage

Use the following procedure to store the pump.

1. Shut down the pump as described in [Section 4.5](#).
2. Isolate the pump from the electrical supply and disconnect it from your vacuum system. Drain the pump fluid as described in [Section 5.4](#).
3. Dismantle, clean and reassemble the pump as described in [Section 5.5](#). Do not refill the pump with fluid.
4. Place protective covers over the inlet and outlet-flanges and cooling-water and pneumatic connection points.
5. Store the pump in cool dry conditions until required for use. When required, prepare and install the pump as described in [Section 3](#).

6.2 Disposal

Dispose of the Diffstak pump and any components safely in accordance with all local and national safety and environmental requirements.

Take particular care with the following:

- Components which have come into contact with pump fluid
- Fluoroelastomers which may have been subjected to temperatures above 315 °C (see [Section 5.1](#))
- Components which have been contaminated with dangerous process substances.

This page has been intentionally left blank.

7 Service, spares and accessories

7.1 Introduction

Edwards products, spares and accessories are available from Edwards companies in Belgium, Brazil, China, France, Germany, Israel, Italy, Japan, Korea, Singapore, United Kingdom, U.S.A, and a world-wide network of distributors. The majority of these centres employ Service Engineers who have undergone comprehensive Edwards training courses.

Order spare parts and accessories from your nearest Edwards company or distributor. When you order, please state for each part required:

- Model and Item Number of your equipment
- Serial number (if any)
- Item Number and description of part.

7.2 Service

Edwards products are supported by a world-wide network of Edwards Service Centres. Each Service Centre offers a wide range of options including: equipment decontamination; service exchange; repair; rebuild and testing to factory specifications. Equipment which has been serviced, repaired or rebuilt is returned with a full warranty.

Your local Service Centre can also provide Edwards engineers to support on-site maintenance, service or repair of your equipment.

For more information about service options, contact your nearest Service Centre or other Edwards company.

7.3 Spares

7.3.1 Pump fluids

Fluid	Item Number
Santovac 5 (500 ml x 12)	H114-01-003
DC702 (25 kg)	H112-03-029
DC704EU (25 kg)	H112-01-045
DC705 (5 kg)	H112-02-023
Apiezon C (500 ml)	H023-00-039

7.3.2 Spares common to all Diffstak pumps

Spare	Pump model			
	63/150	100/300	160/700*	250/2000*
Heater: 100 to 125 V	H017-00-182 (0.45 kW)	H017-00-199 (0.65 kW)	H017-00-102 (0.35 kW)	H017-00-140 (0.85 kW)
			H017-00-059 (1.0 kW)	H017-00-161 (1.4 kW)
Heater: 210 to 225 V	H017-00-186 (0.45 kW)	H017-00-097 (0.65 kW)	H017-00-107 (0.35 kW)	H017-00-134 (0.85 kW)
			H017-00-63 (1.0 kW)	H017-00-155 (1.4 kW)
Heater: 230 to 250 V	H017-00-191 (0.45 kW)	H017-00-190 (0.65 kW)	H017-00-113 (0.35 kW)	H017-00-137 (0.85 kW)
			H017-00-54 (1.0 kW)	H017-00-158 (1.4 kW)
Backing 'O' ring assembly (fluoroelastomer)	C105-11-395	C105-14-395	C105-14-395	C105-16-395
Drain and filler-plug 'O' rings VIT 0056-24 (pack of 5)	H021-23-027	H021-23-027	H021-23-027	H021-23-027

7.3.3 Spares for Diffstak M- and P-model pumps

Spare	Pump model			
	63/150	100/300	160/700	250/2000
Valve-plate 'O' ring	H021-06-050 VIT 0335	H021-06-061 VIT 0346	H021-02-221 VIT 1221	H021-06-093 VIT 0449
Valve shaft seal 'O' ring	H021-06-010 VIT 0012▲	H021-06-010 VIT 0012▲	H021-06-011 VIT 0111▲	H021-06-121 VIT 1121†
Valve blanking plate 'O' ring	H021-06-010 VIT 0012▲	H021-06-010 VIT 0012▲	H021-06-011 VIT 0111▲	H021-06-128 VIT 1128†
Position indicator spares kit◆	B344-32-023	B344-32-023	B344-32-023	B3 44-32-023

* One heater of each power rating is required for the 160/700 and 250/2000 Diffstak pumps.

▲ Pack of 5

† Pack of 2

◆ P-model pumps only

7.4 Accessories

Note: Refer to Figures 12 and 13 and Section 3 for installation details for a Diffstak pump.

Accessory	Item Number			
	ISO63	ISO100	ISO160	ISO250
Cooling-fail thermal snap-switch		B023-02-000		
Pump-ready thermal snap-switch		B023-04-000		
Claw clamp (pack of 2)		C100-07-090		
ISO tube and collar assembly	C100-07-032	C100-09-032	C100-11-032	C100-13-032
Rotatable flange pack	C100-07-010	C100-09-010	C100-11-010	C100-13-010
Pump inlet seal (fluoroelastomer)	B271-58-064*	B271-58-071*	B271-58-074*	B271-58-143†
		NW10	NW25	NW40
BRVMK valve		C321-03-000	C323-03-000	-
BRVPK valve		C321-04-000	C323-04-000	-
PV40MK valve, aluminium, manual		-	-	C134-05-000
PV40PK valve, aluminium, 'O' ring sealed, pneumatic		-	-	C414-13-000
Clamp		C105-12-401	C105-14-401	C105-16-401
'O' ring assembly, polymer/nitrile		C105-11-393	C105-14-393	C105-16-393
NW40 elbow, aluminium		-	-	C105-16-410
NW40 T-piece, aluminium		-	-	C105-16-411
Electropneumatic control-valves				
3-port control-valves				
24 V d.c.		H062-00-124		
24 V a.c., 1-phase, 50/60 Hz		H062-00-125		
110 V a.c., 1-phase, 50/60 Hz		H062-00-126		
230 V a.c., 1-phase, 50/60 Hz		H062-00-138		
Lightweight 5-port electropneumatic control-valve kits				
24 V a.c., 1-phase, 50/60 Hz		B287-03-030		
110 V a.c., 1-phase, 50/60 Hz		B287-03-031		
230 V a.c., 1-phase, 50/60 Hz		B287-03-032		
24 V d.c.		B287-03-055		
Standard 5-port control-valves				
110 V a.c., 1-phase, 50/60 Hz		H062-00-136		
230 V a.c., 1-phase, 50/60 Hz		H062-00-137		

* Co-Seal, polymer/fluoroelastomer

† Trapped 'O' ring assembly

This page has been intentionally left blank.